

# OPERATOR'S MANUAL

## IS3100Z Series Zero-Turn Riding Mower

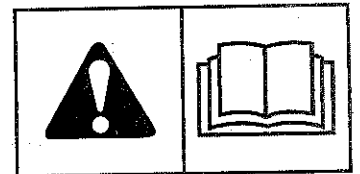
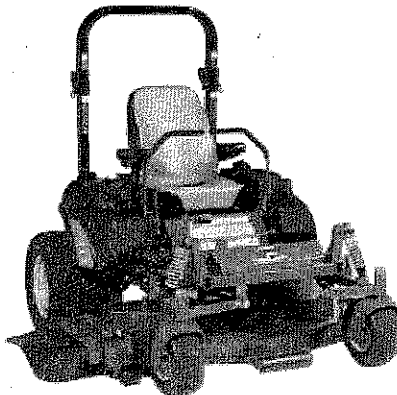

### Zero-Turn Rider & Mower Deck

| Model No.: | Description           |
|------------|-----------------------|
| 5900784    | IS3100ZLKAV2661       |
| 5900788    | IS3100ZBV3061         |
| 5900786    | IS3100ZBV3261         |
| 5900791    | IS3100ZBV32/61 AUS/NZ |
| 5900793    | IS3100ZBV3261CAL      |
| 5900794    | IS3100ZKAV3761SS      |
| 5900872    | IS3100ZKAV3761SS DFI  |
| 5900969    | IS3100ZKAV3761        |
| 5900559    | IS3100ZB3061          |
| 5900302    | IS3100ZBV3061         |
| 5900301    | IS3100ZBV3661         |
| 5900561    | IS3100ZKAV3861        |

### Zero-Turn Rider

| Model No.: | Description        |
|------------|--------------------|
| 5900787    | IS3100ZBV32        |
| 5900792    | IS3100ZBV32AUS/NZ  |
| 5900795    | IS3100ZKAV37SS     |
| 5900873    | IS3100ZKAV37SS DFI |
| 5900970    | IS3100ZKAV37       |
| 5900300    | IS3100ZBV36        |
| 5900560    | IS3100ZKAV38       |

### 72" Mower Deck Flat Nosed

| Model No.: | Description    |
|------------|----------------|
| 5901184    | 3100/72        |
| 5900718    | 3100/72 AUS/NZ |

### 72" Mower Deck iCD Slope Nosed

| Model No.: | Description |
|------------|-------------|
| 5900510    | 3100/72     |

# Table of Contents

---

|  |           |   |           |
|--|-----------|---|-----------|
| <b>Operator Safety</b> .....                     | <b>2</b>  | <b>Troubleshooting, Adjustments &amp; Service</b> ..... | <b>33</b> |
| Identification Numbers .....                     | 11        | Troubleshooting the Rider .....                         | 33        |
| Safety Decals & Icons.....                       | 12        | Troubleshooting the Mower .....                         | 34        |
| Safety Icons & Interlock System .....            | 13        | Troubleshooting Common Cutting Problems.....            | 35        |
| <b>Features &amp; Controls</b> .....             | <b>14</b> | Seat Adjustment.....                                    | 36        |
| Control Functions.....                           | 14        | Ground Speed Control Lever Adjustment.....              | 36        |
| <b>Operation</b> .....                           | <b>16</b> | Speed Balancing Adjustment.....                         | 37        |
| General .....                                    | 16        | Neutral Adjustment .....                                | 37        |
| Checks Before Starting.....                      | 16        | Return-To-Neutral Adjustment .....                      | 38        |
| Starting the Engine .....                        | 17        | Parking Brake Adjustment .....                          | 38        |
| Stopping the Rider .....                         | 17        | Suspension Adjustment .....                             | 39        |
| Pushing the Rider by Hand.....                   | 17        | Cutting Height Adjustment.....                          | 40        |
| Zero Turn Driving Practice.....                  | 18        | Foot Pedal Adjustment .....                             | 40        |
| Mowing.....                                      | 20        | Deck Lift Rod Timing Adjustment .....                   | 41        |
| Mowing Recommendations.....                      | 20        | Deck Leveling Adjustment .....                          | 42        |
| Mowing Methods.....                              | 21        | Deck Lift Spring .....                                  | 42        |
| Attaching a Trailer.....                         | 22        | PTO Clutch Adjustment .....                             | 43        |
| Raising & Lowering the Roll Bar.....             | 23        | Blade Brake Check.....                                  | 44        |
| Storage .....                                    | 24        | Hydraulic Pump Drive Belt Replacement .....             | 45        |
| Starting After Long Term Storage.....            | 24        | Mower Belt Replacement.....                             | 46        |
| <b>Regular Maintenance</b> .....                 | <b>25</b> | Battery Service.....                                    | 47        |
| Maintenance Schedule .....                       | 25        | <b>Specifications</b> .....                             | <b>49</b> |
| Check Engine Oil Level .....                     | 25        | <b>Slope Identification Guide</b> .....                 | <b>50</b> |
| Engine Maintenance .....                         | 25        |   |           |
| Checking Tire Pressures .....                    | 26        |   |           |
| Checking / Adding Fuel.....                      | 26        |   |           |
| Fuel Filter .....                                | 26        |   |           |
| Oil & Filter Change .....                        | 26        |   |           |
| Check Hydraulic Oil Level.....                   | 27        |   |           |
| Hydraulic Oil Filter Change.....                 | 27        |   |           |
| Cooling System (Liquid Cooled Models Only) ..... | 28        |   |           |
| Lubrication .....                                | 29        |   |           |
| Battery Maintenance .....                        | 30        |   |           |
| Anti-Scalp Deck Casters.....                     | 30        |   |           |
| Servicing the Mower Blades .....                 | 31        |   |           |

---

*NOTE: In this manual, "left" and "right" are referred to as seen from the operating position.*

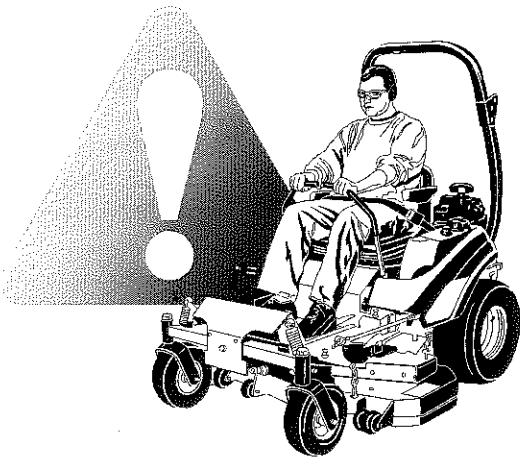

## Operating Safety

Congratulations on purchasing a superior-quality piece of lawn and garden equipment. Our products are designed and manufactured to meet or exceed all industry standards for safety.

Do not operate this machine unless you have been trained. Reading and understanding this operator's manual is a way to train yourself.

Power equipment is only as safe as the operator. If it is misused, or not properly maintained, it can be dangerous! Remember, you are responsible for your safety and that of those around you.

Use common sense, and think through what you are doing. If you are not sure that the task you are about to perform can be safely done with the equipment you have chosen, ask a professional: contact your local authorized dealer.

## Read the Manual

The operator's manual contains important safety information you need to be aware of **BEFORE** you operate your unit as well as **DURING** operation.

Safe operating techniques, an explanation of the product's features and controls, and maintenance information is included to help you get the most out of your equipment investment.

Be sure to completely read the Safety Rules and Information found on the following pages. Also completely read the Operation section.

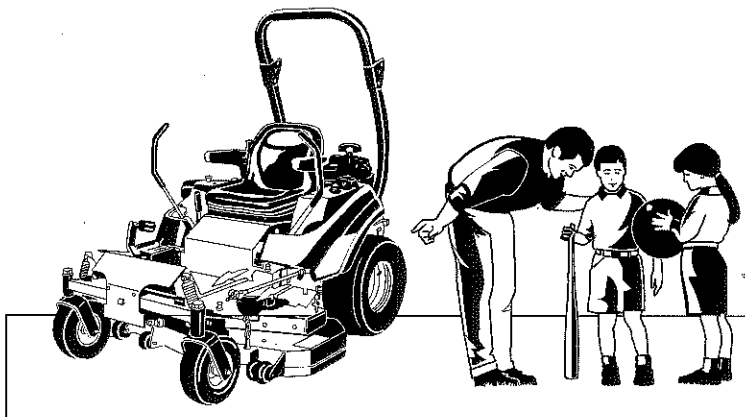
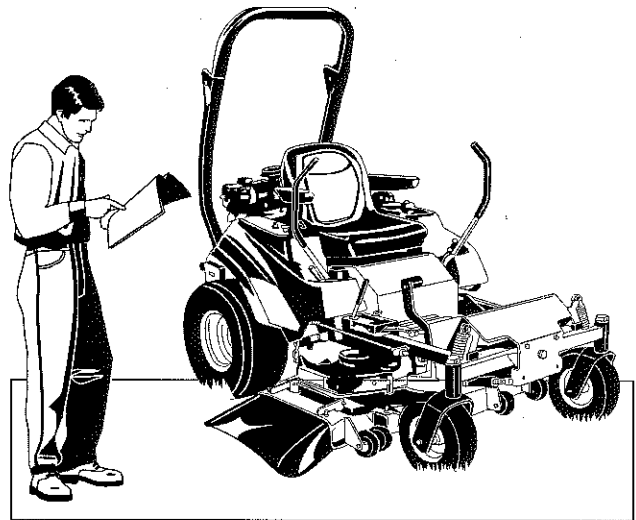

## Children

Tragic accidents can occur with children. Do not allow them anywhere near the area of operation. Children are often attracted to the unit and mowing activity. Never assume that children will remain where you last saw them. If there is a risk that children may enter the area where you are mowing, have another responsible adult watch them.

## Slope Operation



5.4

20

Operation on slopes can be dangerous. Using the unit on a slope that is too steep where you do not have adequate wheel traction (and control) can cause sliding, loss of steering, control, and possible rollover. You should not operate on a slope greater than a 5.4 foot rise over a 20 foot length (15 degrees).

Always mow across slopes, not up and down (to maintain traction on the wheels) and avoid sudden turns or rapid speed changes. Reduce speed and use extreme caution on ALL slopes.

Also, note that the surface condition you are on can greatly impact your ability to safely operate this machine. Operating on wet or slippery slopes can cause sliding and loss of steering and control. Do not operate on slopes that are slippery, wet, or have soft soil conditions.

If you feel unsure about operating the unit on a slope, don't do it. It's not worth the risk.

## Thrown Objects

This unit has spinning mower blades. These blades can pick up and throw debris that could seriously injure a bystander. Be sure to clean up the area to be mowed and remove objects that could be thrown by the blade **BEFORE** you start mowing.

Do not operate this unit without the entire grass catcher or discharge guard (deflector) in place.

Also, do not allow anyone in the area while the unit is running! If someone does enter the area, shut the unit off immediately until they leave.

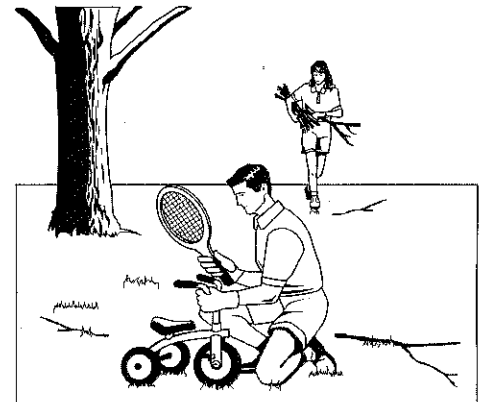

## Moving Parts

This equipment has many moving parts that can injure you or someone else. However, if you stay in the operator zone (stay seated in the seat), and follow the safety rules in this operator's manual, the unit is safe to operate.

The mower deck has spinning mower blades that can amputate hands and feet. Do not allow anyone near the unit while it is running! Keep safety devices (guards, shields, and switches) in place and working.

To help you, the operator, use this equipment safely, it is equipped with an operator-present safety system. Do **NOT** attempt to alter or bypass the system. See your dealer immediately if the system does not pass all the safety interlock system tests found in this manual.

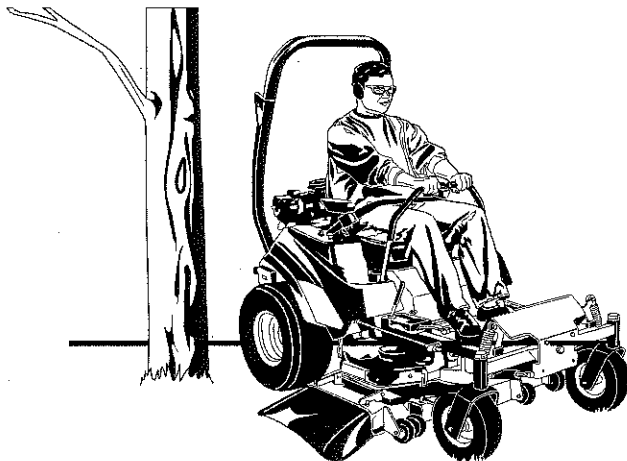



## Roll Bar Use

Keep the roll bar in the raised position and fasten the seat belt. There is no roll over protection when the roll bar is down! Do not jump off if the mower tips (it is safer to be secured by the seat belt with the roll bar raised.)

Lower the roll bar only when necessary (such as to temporarily clear a low overhanging obstacle) and NEVER remove it. Do NOT use the seat belt when the roll bar is down. Raise the roll bar as soon as clearance permits.

## Retaining Walls, Drop-offs, and Water

Retaining walls and drop-offs around steps and water are a common hazard. Give yourself a minimum of two mower widths of clearance around these hazards and hand-trim with a walk behind mower or string trimmer. Wheels dropping over retaining walls, edges, ditches, embankments, or into water can cause rollovers, which may result in serious injury, death, or drowning.

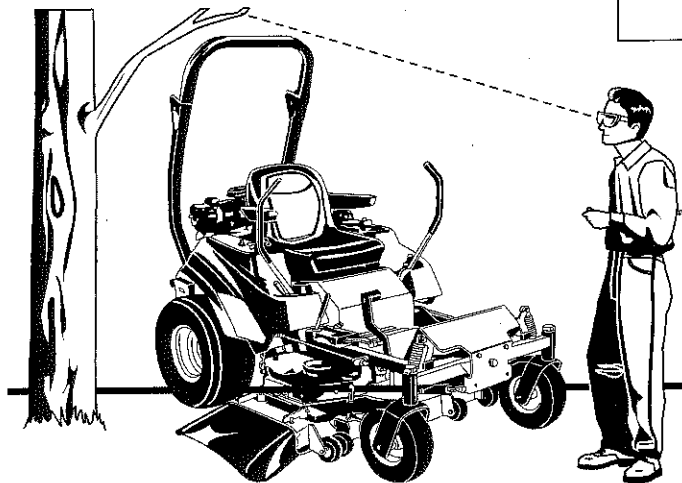
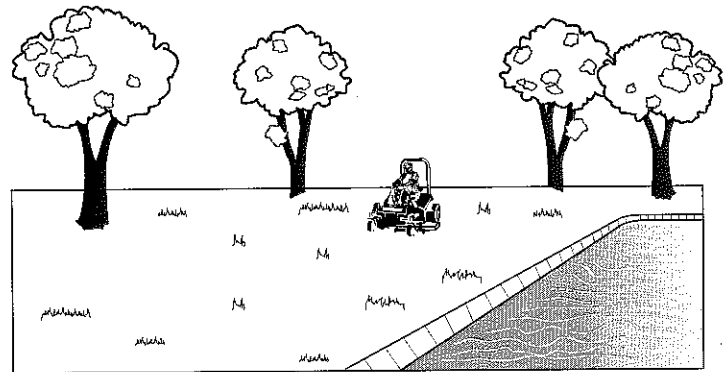
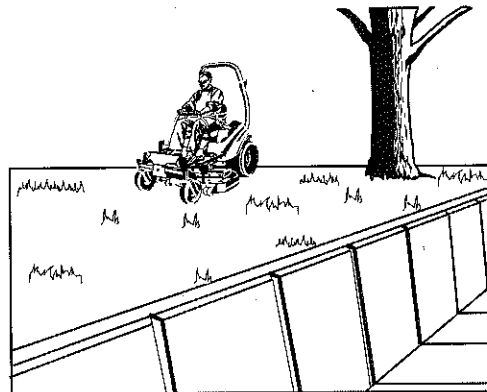

## Overhead Obstacles

Check for overhead clearances before driving under any objects. Do not allow the roll bar to contact low overhanging obstacles such as tree branches and guide wires.

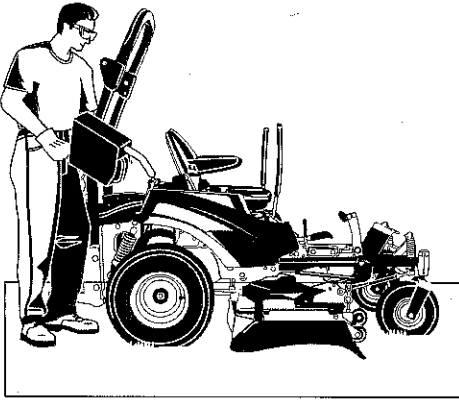

## Fuel and Maintenance

Always disengage all drives, shutoff the engine, and remove the key before doing any cleaning, refueling, or servicing.

Gasoline and its vapors are extremely flammable. Do not smoke while operating or refueling. Do not add fuel while engine is hot or running. Allow engine to cool for at least 3 minutes prior to adding fuel.

Do not add fuel indoors, in an enclosed trailer, garage, or any other enclosed area that is not well ventilated. Gasoline spills should be cleaned up promptly and before operation begins.

Gasoline should be stored only in sealed containers approved for fuel.

Proper maintenance is critical to the safety and performance of your unit. Keep the unit free of grass, leaves, and excess oil. Be sure to perform the maintenance procedures listed in this manual, especially periodically testing the safety system.

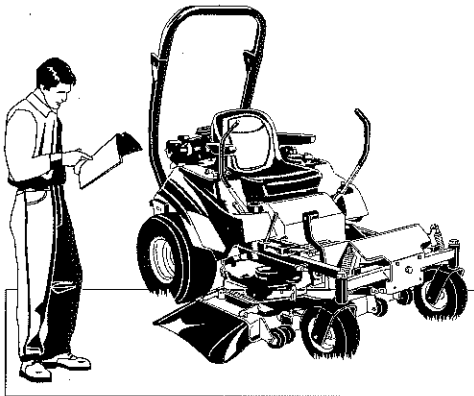

## Enclosed Areas

Only operate this unit outdoors and away from unventilated areas such as inside garages or enclosed trailers. The engine emits poisonous carbon monoxide gas and prolonged exposure in an enclosed area can result in serious injury or death.

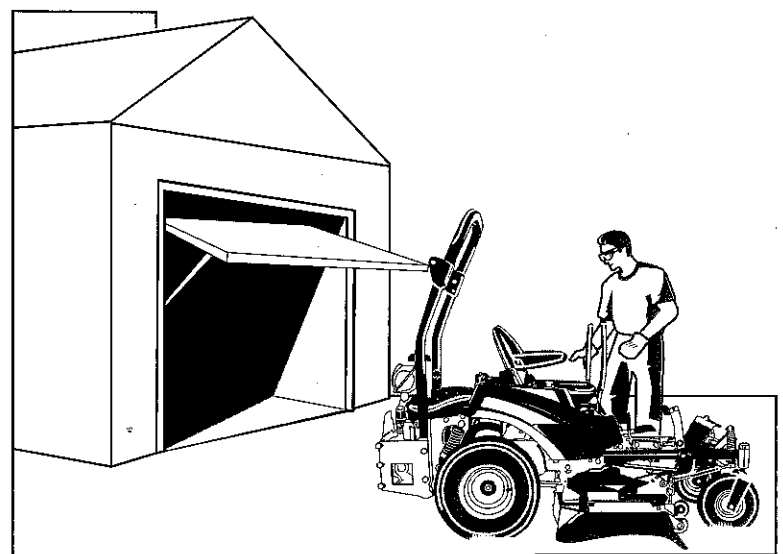

# Operator Safety



Read these safety rules and follow them closely. Failure to obey these rules could result in loss of control of unit, severe personal injury or death to you, or bystanders, or damage to property or equipment. **This mowing deck is capable of amputating hands and feet and throwing objects.** The triangle  in text signifies important cautions or warnings which must be followed.

## TRAINING

1. Read, understand, and follow all instructions in the manual and on the unit before starting. If the operator(s) or mechanic(s) can not read English it is the owner's responsibility to explain this material to them.
2. Become familiar with the safe operation of the equipment, operator controls, and safety signs.
3. All operators and mechanics should be trained. The owner is responsible for training the users.
4. Only allow responsible adults, who are familiar with the instructions, to operate the unit.
5. Never let children or untrained people operate or service the equipment. Local regulations may restrict the age of the operator.
6. The owner/user can prevent and is responsible for accidents or injuries occurring to themselves, other people or property.
7. Data indicates that operators, age 60 years and above, are involved in a large percentage of riding mower-related injuries. These operators should evaluate their ability to operate the riding mower safely enough to protect themselves and others from serious injury.
2. Mow only in the daylight or with good artificial light, keeping away from holes and hidden hazards.
3. Be sure all drives are in neutral and parking brake is engaged before starting engine. Only start engine from the operator's position. Use seat belts if provided.
4. Be sure of your footing while using pedestrian controlled equipment, especially when backing up. Walk, don't run. Reduced footing could cause slipping.
5. Slow down and use extra care on hillsides. Be sure to travel in the recommended direction on hillsides. Turf conditions can affect the machines stability. Use caution when operating near drop-offs.
6. Do not mow in reverse unless absolutely necessary. Always look down and behind before and while traveling in reverse.
7. Be aware of the mower discharge direction and do not point it at anyone. Do not operate the mower without either the entire grass catcher or the deflector in place.
8. Slow down and use caution when making turns and when changing directions on slopes.
9. Never raise deck with the blades running.
10. Never leave a running unit unattended. Always disengage the PTO, set parking brake, stop engine, and remove keys before dismounting. Keep hands and feet away from the cutting units.
11. Turn off the PTO switch to disengage the blades when not mowing.
12. Never operate with guards not securely in place. Be sure all interlocks are attached, adjusted properly and functioning properly.
13. Never operate with the discharge deflector raised, removed or altered, unless using a grass catcher.
14. Do not change the engine governor setting or overspeed the engine.
15. Stop on level ground, lower implements, disengage drives, engage parking brake, shut off engine before leaving the operator's position for any reason including emptying the grass catchers or unclogging the chute.
16. Stop equipment and inspect blades after striking objects or abnormal vibration occurs. Make necessary repairs before resuming operations.
17. Keep hands and feet away from the cutting units.
18. Look behind and down before backing up to be sure of a clear path.
19. Never carry passengers and keep pets and bystanders away.
20. Do not operate the unit while under the influence of alcohol or drugs.
21. Slow down and use caution when making turns and crossing roads and sidewalks. Stop blades if not mowing.
22. Use care when loading or unloading the machine into a trailer or truck.

## PREPARATION

1. Evaluate the terrain to determine what accessories and attachments are needed to properly and safely perform the job. Use only accessories and attachments approved by the manufacturer.
2. Wear appropriate clothing including safety shoes, safety glasses and ear protection. Long hair, loose clothing or jewelry may get tangled in moving parts.
3. Inspect the area where the equipment is to be used and remove all objects such as rocks, toys and wire, which can be thrown by the machine.
4. Use extra care when handling gasoline and other fuels. They are flammable and vapors are explosive.
  - a) Use only an approved container.
  - b) Never remove fuel cap or add fuel with the engine running. Allow engine to cool before refueling. Do not smoke.
  - c) Never refuel or drain the machine indoors.
5. Check that operator's presence controls, safety switches and shields are attached and functioning properly. Do not operate unless they are functioning properly.

## OPERATION

1. Never run an engine in an enclosed area.

23. Use care when approaching blind corners, shrubs, trees or other objects that may obscure vision.
24. To reduce fire hazard, keep unit free of grass, leaves & excess oil. Do not stop or park over dry leaves, grass or combustible materials.

## WARNING

It is a violation of California Public Resource Code, Section 4442, to use or operate the engine on any forest-covered, brush-covered or grass-covered land unless the exhaust system is equipped with a spark arrester, as defined in Section 4442, maintained in effective working order. Other states or federal jurisdictions may have similar laws. Contact an Authorized Service Dealer to obtain a spark arrester designed for the exhaust system installed on this engine.

25. OSHA regulations may require the use of hearing protection when exposed to sound levels greater than 85 dBA for an 8 hour time period.

## CAUTION



This machine produces sound levels in excess of 85 dBA at the operator's ear and can cause hearing loss though extended periods of exposure.

**Wear hearing protection when operating this machine.**

## SLOPE OPERATION

Slopes are a major factor related to loss-of-control and tip-over accidents, which can result in severe injury or death. All slopes require extra caution. If you cannot back up the slope or if you feel uneasy on it, do not drive on it.

## WARNING

**Do not use this machine on slopes greater than 15°.\***

**Select slow ground speed before driving onto slope. Use extra caution when operating on slopes with rear-mounted grass catchers.**

**Mow across the face of slopes, not up and down, use caution when changing directions and DO NOT START OR STOP ON SLOPE.**

### Do

1. Mow across slopes, not up and down.
2. Remove obstacles such as rocks, tree limbs, etc.
3. Watch for holes, ruts, or bumps. Uneven terrain could overturn the unit. Tall grass can hide obstacles.
4. Use slow speed. Choose a slow speed so that you will not have to stop or change speed while on the slope.

\*This limit was determined per CEN Standard EN 836:1997, Section 5.2.2 and is based on the EN 836 Stability Test procedure described in Section 4.2.4.2. The 15 degree "limit of stability" is equal to 50% of the angle at which machine lift-off occurred in static tests. Actual dynamic stability may vary depending on operating conditions.

5. Use extra care with grass catchers or other attachments. These can change the stability of the unit.
6. Keep all movement on the slopes slow and gradual. Do not make sudden changes in speed or direction.
7. See your authorized dealer for recommendations of available weights to improve stability.

### Do Not

1. Avoid starting, stopping, or turning on a slope. If tires lose traction (i.e. machine stops forward motion on a slope), disengage the blade(s) (PTO) and drive slow off the slope.
2. Do not turn on slopes unless necessary, and then, turn slowly and gradually uphill, if possible. Never mow down slopes.
3. Do not mow near drop-offs, ditches, or embankments. The operator could lose footing or balance or mower could suddenly turn over if a wheel is over the edge of a cliff or ditch, or if an edge caves in.
4. Do not mow on wet grass. Reduced footing or traction could cause sliding.
5. Do not try to stabilize the unit by putting your foot on the ground. (ride-on units)
6. Do not mow excessively steep slopes.
7. Do not use grass catcher on steep slopes.
8. Do not mow slopes if you cannot back up them.

## TOWED EQUIPMENT (RIDE-ON UNITS)

1. Tow only with a machine that has a hitch designed for towing. Do not attach towed equipment except at the hitch point.
2. Follow the manufacturer's recommendations for weight limit for towed equipment and towing on slopes. See attaching a trailer under OPERATION.
3. Never allow children or others in or on towed equipment.
4. On slopes, the weight of the towed equipment may cause loss of traction and loss of control.
5. Travel slowly and allow extra distance to stop.
6. Do not shift to neutral and coast down hill.

## CHILDREN

Tragic accidents can occur if the operator is not alert to the presence of children. Children are often attracted to the unit and the mowing activity. Never assume that children will remain where you last saw them.

1. Keep children out of the mowing area and under the watchful care of another responsible adult.
2. Be alert and turn unit off if children enter the area.
3. Before and during reverse operation, look behind and down for small children.
4. Never carry children, even with the blade(s) off. They may fall off and be seriously injured or interfere with safe unit operation. Children who have been given rides in the past may suddenly appear in the mowing area for another ride and be run over or backed over by the machine.
5. Never allow children to operate the unit.
6. Use extra care when approaching blind corners, shrubs, trees, or other objects that may obscure vision.

# Operator Safety

## EMISSIONS

1. Engine exhaust from this product contains chemicals known, in certain quantities, to cause cancer, birth defects, or other reproductive harm.
2. Look for the relevant Emissions Durability Period and Air Index information on the engine emissions label.

## IGNITION SYSTEM (GASOLINE MODELS)

1. This spark ignition system complies with Canadian ICES-002.

## SERVICE AND MAINTENANCE

**To avoid personal injury or property damage, use extreme care in handling gasoline. Gasoline is extremely flammable and the vapors are explosive.**

### Safe Handling of Gasoline

1. Extinguish all cigarettes, cigars, pipes, and other sources of ignition.
2. Use only approved gasoline containers.
3. Never remove the gas cap or add fuel with the engine running. Allow the engine to cool before refueling.
4. Never fuel the machine indoors.
5. Never store the machine or fuel container where there is an open flame, spark, or pilot light such as near a water heater or other appliance.
6. Never fill containers inside a vehicle or on a truck bed with a plastic bed liner. Always place containers on the ground away from your vehicle before filling.
7. Remove gas-powered equipment from the truck or trailer and refuel it on the ground. If this is not possible, then refuel such equipment on a trailer with a portable container, rather than from a gasoline dispenser nozzle.
8. Keep nozzle in contact with the rim of the fuel tank or container opening at all times until fueling is complete. Do not use a nozzle lock-open device.
9. If fuel is spilled on clothing, change clothing immediately.
10. Never over-fill the fuel tank. Replace gas cap and tighten securely.
11. Use extra care in handling gasoline and other fuels. They are flammable and vapors are explosive.
12. If fuel is spilled, do not attempt to start the engine but move the machine away from the area of spillage and avoid creating any source of ignition until fuel vapors have dissipated.
13. Replace all fuel tank caps and fuel container caps securely.

### Maintenance and Storage

1. Always observe safe refueling and fuel handling practices when refueling the unit after transportation or storage.
2. Always follow the engine manual instructions for storage preparations before storing the unit for both short and long term periods.
3. Always follow the engine manual instructions for proper start-up procedures when returning the unit to service.
4. Never store the machine or fuel container inside

- where there is an open flame, such as in a water heater. Allow unit to cool before storing.
5. Shut off fuel while storing or transporting. Do not store fuel near flames or drain indoors.
6. Keep all hardware, especially blade attachment bolts, tight and keep all parts in good working condition. Replace all worn or damaged decals.
7. Never tamper with safety devices. Check their proper operation regularly.
8. Disengage drives, lower implement, set parking brake, stop engine and remove key or disconnect spark plug wire. Wait for all movement to stop before adjusting, cleaning or repairing.
9. Clean grass and debris from cutting units, drives, mufflers, and engine to prevent fires. Clean up oil or fuel spillage.
10. Let engine cool before storing and do not store near flame.
11. Stop and inspect the equipment if you strike an object. Repair, if necessary, before restarting.
12. Park machine on level ground. Never allow untrained personnel to service machine.
13. Use jack stands to support components when required.
14. Carefully release pressure from components with stored energy.
15. Disconnect battery or remove spark plug wire before making any repairs. Disconnect the negative terminal first and the positive last. Reconnect positive first and negative last.
16. Use care when checking blades. Wrap the blade(s) or wear gloves, and use caution when servicing them. Only replace blades. Never straighten or weld them.
17. Keep hands and feet away from moving parts. If possible, do not make adjustments with the engine running.
18. Charge batteries in an open well ventilated area, away from spark and flames. Unplug charger before connecting or disconnecting from battery. Wear protective clothes and use insulated tools.
19. Grass catcher components are subject to wear, damage, and deterioration, which could expose moving parts or allow objects to be thrown. Frequently check components and replace with manufacturer's recommended parts, when necessary.
20. Check brake operation frequently. Adjust and service as required.
21. Use only factory authorized replacement parts when making repairs.
22. Always comply with factory specifications on all settings and adjustments.
23. Only authorized service locations should be utilized for major service and repair requirements.
24. Never attempt to make major repairs on this unit unless you have been properly trained. Improper service procedures can result in hazardous operation, equipment damage and voiding of manufacturer's warranty.
25. Units with hydraulic pumps, hoses, or motors: **WARNING:** Hydraulic fluid escaping under pressure may have sufficient force to penetrate skin and cause serious injury. If foreign fluid is injected into the skin it must be surgically removed within a few hours by a doctor familiar with this form of injury or gangrene may result. Keep body and hands away from pin holes or nozzles that eject hydraulic fluid under high pressure. Use paper or cardboard, and not hands, to search for

leaks. Make sure all hydraulic fluid connections are tight and all hydraulic hoses and lines are in good condition before applying pressure to the system. If leaks occur, have the unit serviced immediately by your authorized dealer.

26. **WARNING:** Stored energy device. Improper release of springs can result in serious personal injury. Springs should be removed by an authorized technician.
27. Models equipped with an engine radiator: **WARNING:** Stored energy device. To prevent serious bodily injury from hot coolant or steam blow-out, never attempt to remove the radiator cap while the engine is running. Stop the engine and wait until it is cool. Even then, use extreme care when removing the cap.

## ROLL BAR INSTRUCTIONS

For models equipped with factory-installed Roll Over Protection System (ROPS).

### **WARNING**

In order to avoid serious injury or death from roll over, it is important to follow the warnings listed below.

#### OPERATIONAL WARNINGS

- Always use the seat belt when the roll bar is in the raised position.
- Never use the seat belt when the roll bar is in the down position.
- Remember there is no roll over protection when the roll bar is in the down position so it is very important to always keep the roll bar in the raised position whenever possible.
- Lower the roll bar to the down position only when it is absolutely necessary.
- Check for overhead clearances before driving under any objects. Do not allow roll bar to contact low overhanging obstacles such as tree branches and guide wires.
- Never remove the roll bar from the vehicle.
- Do not exceed the machine weight rating of the roll bar.
- Read and follow all of the instructions shown below regarding the inspection and maintenance of the roll bar structure and the seat belt.

#### INSPECTION OF THE ROLL BAR PROTECTIVE STRUCTURE

### **WARNING**

Failure to properly inspect and maintain the ROLL BAR protective structure can cause serious injury or death.

A ROLL BAR, like any other safety device, needs to be periodically inspected to verify that the integrity of the device has not been compromised through normal machine use, misuse, age degradation, modifications, or a roll over.

To maintain operator roll over protection and roll bar effectiveness:

- If a ROLL BAR becomes damaged for any reason, such as a collision, roll over or impact, the ROLL BAR must be replaced. Small undetectable cracks can reduce the effectiveness of the ROLL BAR. Never weld, straighten, or repair the ROLL BAR.
- Never alter the ROLL BAR by welding anything to it or by drilling additional holes.
- **BEFORE FIRST TIME USE** - Inspect the ROLL BAR structure and mounting hardware for:
  - 1) Check to make sure the machine GVW (Gross Vehicle Weight), including attachments, restrained payload, fuel and operator, is not in excess of the maximum weight specified on the ROLL BAR label.
  - 2) Make sure there isn't any missing, damaged, or loose mounting hardware.
  - 3) Make sure the ROLL BAR has been correctly and completely installed.
- **EVERY 100 HOURS** - Inspect the ROLL BAR structure and mounting hardware for:
  - 1) Any cracks in the structure (structural members and/or welds).
  - 2) Significant corrosion on any part of the ROLL BAR structure or hardware.
  - 3) Missing, damaged, or loose mounting hardware
  - 4) Mounting hardware that is of a grade lesser than specified.
  - 5) Machine GVW (Gross Vehicle Weight), including attachments, restrained payload, fuel and operator, in excess of the maximum weight specified on the ROLL BAR label.
  - 6) Any modifications that have been made, such as unauthorized welds and holes.
  - 7) Any permanent deformation or twisting of the ROLL BAR structure.
  - 8) That the ROLL BAR label is still in place and is readable.
  - 9) That the ROLL BAR on-product warning labels are still on the ROLL BAR and are readable.
- If there is any doubt as to the condition of the ROLL BAR, remove the machine from service and contact your dealer for assistance.

## **⚠ WARNING**

Failure to properly inspect and maintain the seat belt can cause serious injury or death.

### **INSPECTION AND MAINTENANCE OF THE ROLL BAR SEAT BELT**

- The seat belt like the ROLL BAR, needs to be periodically inspected to verify that the integrity has not been compromised through normal machine use, misuse, age degradation, modifications, or a roll over. If the seat belt does not pass all of the following tests, it should be replaced.
- **BEFORE EACH USE** – Conduct the following inspections/maintenance of the seat belt and retraction mechanism:
  - 1) Check for dirt or debris in the retraction mechanism. If dirt or debris is found, it should be removed.
  - 2) Check to make sure the retraction mechanism retracts easily and completely.
  - 3) Check for damage to any part of the seat belt such as nicks, cuts, loose stitching, or fraying.
  - 4) Check that the buckle and latch operate properly and that the latch plate is not excessively worn, deformed, or the buckle is damaged or cracked. The seat belt should latch and release easily.

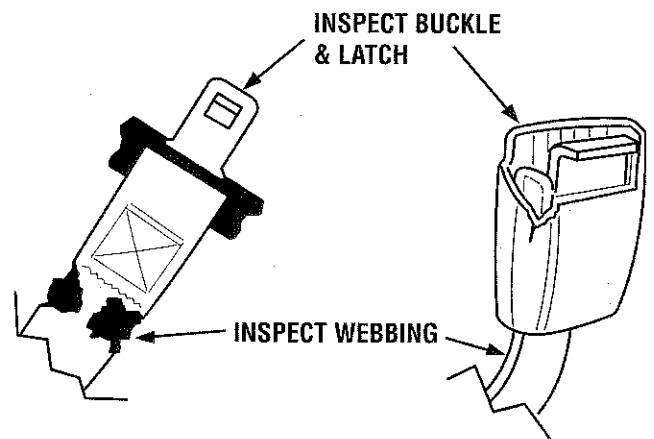

**Identification Numbers**

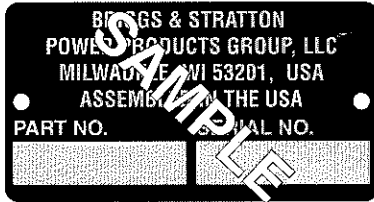

All Models

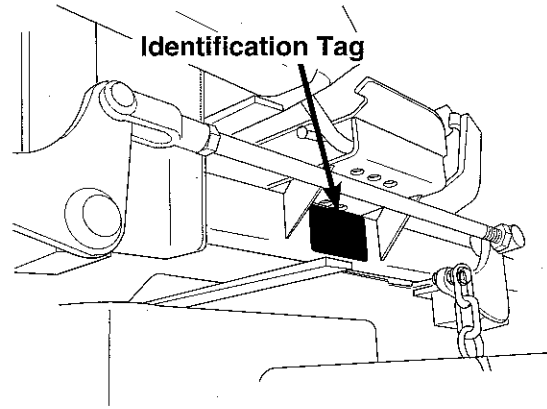

When contacting your authorized dealer for replacement parts, service, or information you **MUST** have these numbers.

Record your model/serial number and engine serial numbers on the space provided for easy access. These numbers can be found in the locations shown.

*NOTE: For location of engine identification numbers, refer to the engine owner's manual.*

# Operator Safety

## Safety Decals

Before operating your unit, read the safety decals. The cautions and warnings are for your safety. To avoid a personal injury or damage to the unit, understand and follow all safety decals.

### **WARNING**

If any safety decals become worn or damaged, and cannot be read, order replacement decals from your local dealer.

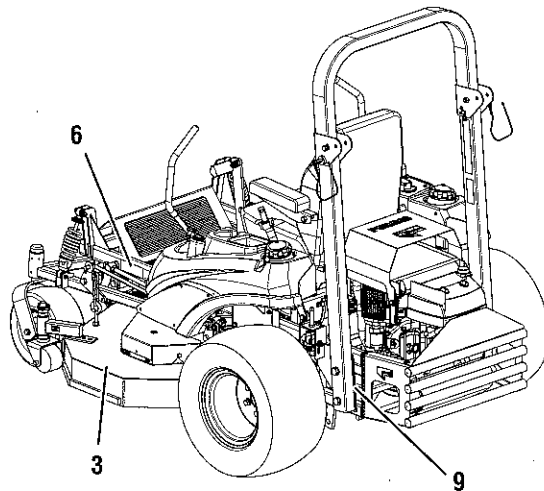
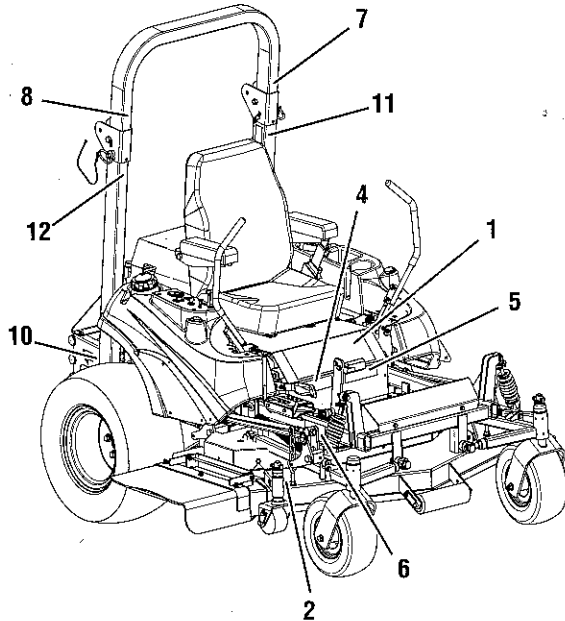

Decals #13 & 14 located near hydraulic pump fans.

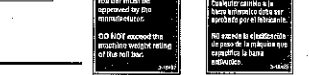
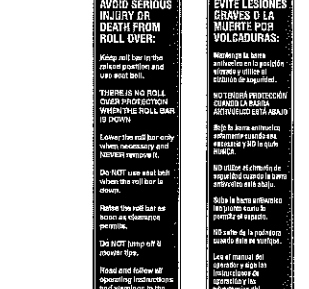
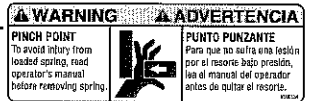
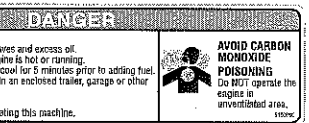
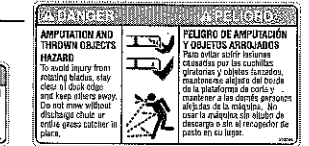
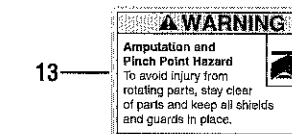
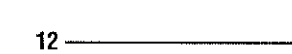
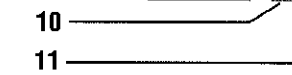
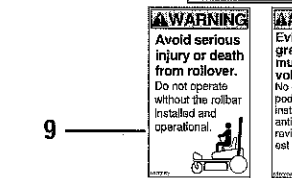
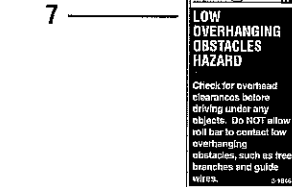
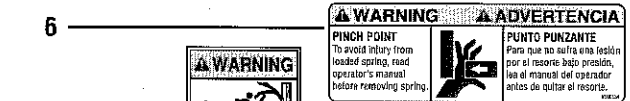
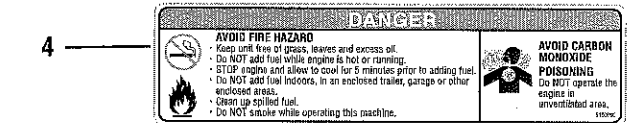
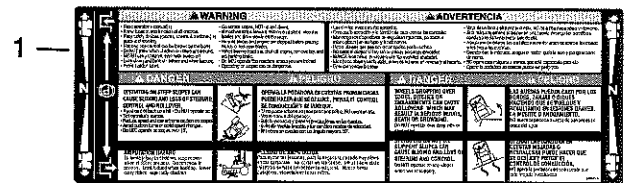



## Safety Interlock System

This unit is equipped with safety interlock switches. These safety systems are present for your safety, do not attempt to bypass safety switches, and never tamper with safety devices. Check their operation regularly.

### Operational SAFETY Checks

#### Test 1 — Engine should NOT crank if:

- PTO switch is engaged, OR
- Parking brake is not engaged, OR
- Motion control handles are not in the NEUTRAL position, OR
- Operator is not on the seat.

#### Test 2 — Engine SHOULD crank if:

- PTO switch is NOT engaged, AND
- Parking brake is engaged, AND
- Motion control handles are locked in the NEUTRAL position, AND
- Operator is on the seat.

#### Test 3 — Engine should SHUT OFF if:

- Operator rises off seat with PTO engaged, OR
- Operator rises off seat with parking brake disengaged.
- Operator moves motion control handles inward before disengaging parking brake.

#### Test 4 — Blade Brake Check

Mower blades and mower drive belt should come to a complete stop within seven (7) seconds after electric PTO switch is turned off (or operator rises off seat). If mower drive belt does not stop within seven (7) seconds, see the PTO Clutch Adjustment section.

*NOTE: Once the engine has stopped, PTO switch must be turned off, parking brake must be engaged, and the motion control handles must be locked in the NEUTRAL position after the operator returns to the seat in order to start the engine.*

## WARNING

If the unit does not pass a safety test, do not operate it. See your authorized dealer. Under no circumstance should you attempt to defeat the purpose of the safety interlock system.

## Safety Icons

The alert symbol is used to identify safety information about hazards that can result in personal injury. A signal word (DANGER, WARNING, or CAUTION) is used with the alert symbol to indicate the likelihood and the potential severity of the injury. In addition, a hazard icon may be used to represent the type of hazard. An explanation of hazard levels and icons are as follows:

### DANGER

This indicates a hazard which, if not avoided, **will result in serious injury or death.**

### WARNING

This indicates a hazard which, if not avoided, **could result in serial injury or death.**

### CAUTION

This indicates a hazard which, if not avoided, **might result in minor or moderate injury.**

### CAUTION or NOTICE

These messages presented without the alert symbol indicate a situation where the unit or property could be damaged.

## North American Safety Icons



Alert



Toxic Fumes



Read the Manual



Open Flame Hazard



Fire Hazard



Amputation Rotating Parts



Amputation Hand in Blade



Amputation Foot in Blade

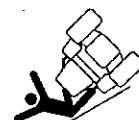

Rollover Hazard



Thrown Objects

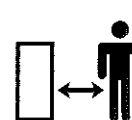

Maintain a Safe Distance

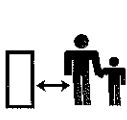

Keep Children Away



Hot Surface



Wear Protective Gear



Pinch Point



Overhead Obstacles



## PTO (Power Take Off) Switch

The PTO switch engages and disengages the mower. Pull UP on the switch to engage the mower, and push DOWN to disengage the mower.

## Throttle Control

Moving the throttle control fully forward is FULL throttle position. Always operate the unit at FULL throttle when mowing.

## Choke

Close the choke for cold starting. Open the choke once the engine starts. A warm engine may not require choking. Pull the knob UP to close the choke. Push to knob DOWN to open the choke.

## Parking Brake

 DISENGAGE Releases the parking brake.

 ENGAGE Locks the parking brake.

Pull the parking brake lever back to engage the parking brake. Move the lever fully forward to disengage the parking brake. *NOTE: To start the unit the parking brake must be engaged.*

## Deck Lift Pedal, Cutting Height Adjustment Pin & Deck Lift Lock Lever

These control the cutting height of the mower deck. Depress the pedal until it locks into the 5" (12,7cm) position. Place the adjustment pin in the desired cutting height and release the lift lock lever.

## Hour Meter

The hour meter measures the number of hours the PTO has been engaged. The hour meter has a self contained power source so the total hours are always visible.

## Fuel Tank Cap

To remove the cap, turn counterclockwise.

## Fuel Level Gauge

Displays the fuel level in the tank.

## Water Temperature Gauge (Liquid Cooled Model only)

Measures the engine coolant temperature.

## Kawasaki DFI Models Control Panel

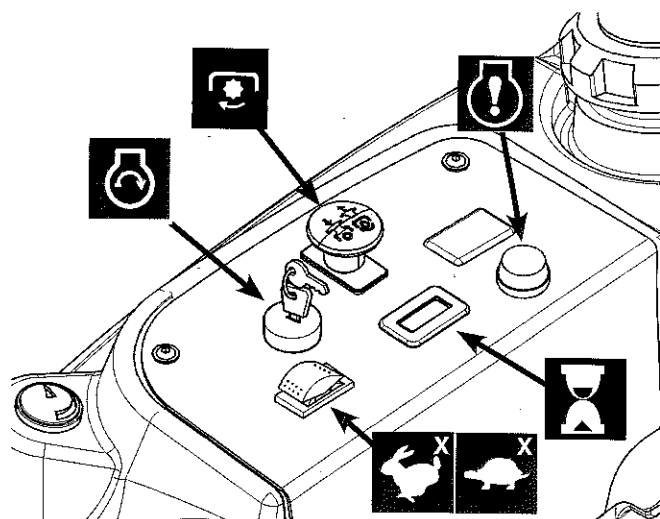

## Throttle Control

Pressing the throttle control rocker switch forward will increase the throttle position. Pressing the throttle control rocker switch backwards will decrease the throttle position. Always operate the unit at FULL throttle when mowing.

## Malfunction Indicator Lamp

The malfunction indicator lamp detects problems with the engine. If the malfunction indicator lamp begins to flash in a sequence while you are operating the unit, see the engine operator's manual.

## Operation

### General Operating Safety

Before first time operation:

- Be sure to read all information in the Safety and Operation sections before attempting to operate this tractor and mower.
- Become familiar with all of the controls and how to stop the unit.
- Drive in an open area without mowing to become accustomed to the unit.

### WARNING

Never operate on slopes greater than 15° which is a rise of 5.4 feet (1,6 m) vertically in 20 feet (6 m) horizontally.

Select slow ground speed before driving onto a slope. Use extra caution when operating on slopes with a rear-mounted grass catcher.

Mow across the face of slopes, not up and down, use caution when changing directions and **DO NOT START OR STOP ON SLOPE.**

### WARNING

Never allow passengers to ride on the unit.

Before leaving the operator's position for any reason, engage the parking brake, disengage the PTO, stop the engine and remove the key.

To reduce fire hazard, keep the engine, tractor and mower free of grass, leaves and excess grease. Do not stop or park tractor over dry leaves, grass or combustible materials.

Gasoline is highly flammable and must be handled with care. Never fill the tank when the engine is still hot from recent operation. Do not allow open flame, smoking or matches in the area. Avoid over-filling and wipe up any spills.

### Checks Before Starting

- Check that crankcase is filled to full mark on dipstick. See the engine Operator's Manual for instructions and oil recommendations.
- Make sure all nuts, bolts, screws and pins are in place and tight.
- Adjust the seat position, and make certain you can reach all controls from operator's position.
- Fill the fuel tank with fresh fuel. Refer to engine manual for fuel recommendations.
- Make sure the fuel valve (D) is in the "ON" position.

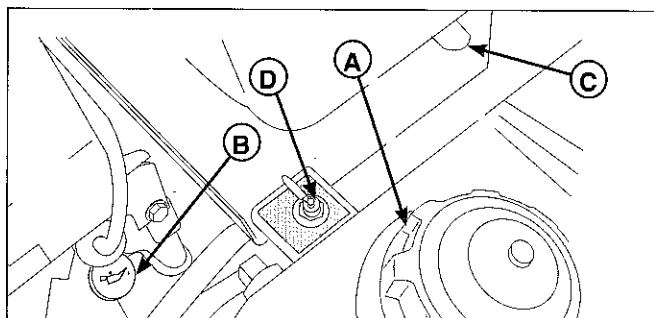
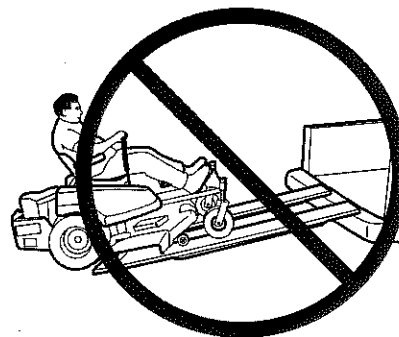

Figure 1. Pre-start Checks

- A. Fuel Tank Cap
- B. Crankcase Oil Fill
- C. Seat Adjustment Lever
- D. Fuel Valve

### WARNING

Do not load this zero-turn rider on a trailer or truck using two separate ramps. Only use a single ramp that is at least one foot wider than the width of the rear wheels of this rider. This rider has a zero turning radius and the rear wheels could fall off the ramps, or the rider could tip over injuring the operator or bystanders.



## **⚠ WARNING**

If you do not understand how a specific control functions, or have not yet thoroughly read the **FEATURES & CONTROLS** section, do so now.

Do **NOT** attempt to operate the tractor without first becoming familiar with the location and function of **ALL** controls.

## Starting the Engine

1. While sitting in the operator's seat, engage the parking brake and make sure the PTO switch is disengaged and the motion control handles are locked in the NEUTRAL position.

### • Carbureted Models

2. **NOTE: A warm engine may not require choking.**

Set the engine throttle control to FAST throttle position. Then fully close the choke by pulling the knob OUT fully.

3. Insert the key into the ignition switch and turn it to START.
4. After the engine starts, gradually open the choke (push knob down fully). Reduce to half throttle speed and allow the engine to warm.

### • DFI Models

2. Insert the key into the ignition switch and turn it to START.
3. The throttle will self adjust to idle when starting. After the engine starts, allow the engine to warm.

*Warm up the engine by running it for at least a minute before engaging the PTO switch or driving the rider.*

### • All Models

1. **After warming the engine, ALWAYS operate the unit at FULL THROTTLE when mowing.**

**In the event of an emergency the engine can be stopped by simply turning the ignition switch to STOP.** Use this method only in emergency situations. For normal engine shut down follow the procedure given in **STOPPING THE RIDER**.

## Stopping the Rider

1. Returning the ground speed control levers to the middle position will stop tractor movement. Pivot the levers outward and lock them in NEUTRAL.
2. Disengage the PTO by pushing down on the PTO switch.
3. Engage the parking brake by pulling the handle up until it locks into position.
4. Move the throttle control to mid-throttle position and turn the ignition key to OFF. Remove the key.

## Pushing the Rider by Hand



### DO NOT TOW RIDER

Towing the unit will cause hydraulic pump and wheel motor damage. Do not use another vehicle to push or pull this unit.

1. Disengage the PTO, engage the parking brake, turn the ignition OFF, and remove the key.
2. Lift the seat plate to gain access to the battery compartment and hydraulic pumps.
3. To disengage the pumps (free-wheel position), turn the hydraulic release valves (A, Figure 2) located on the pumps COUNTER-CLOCKWISE a maximum of 2 full turns.
4. Disengage the parking brake.  
The tractor can now be pushed by hand.
5. After moving the tractor, re-engage the pumps (drive position) by turning the release valves CLOCKWISE and tighten to 80-120 in. lbs. of torque.

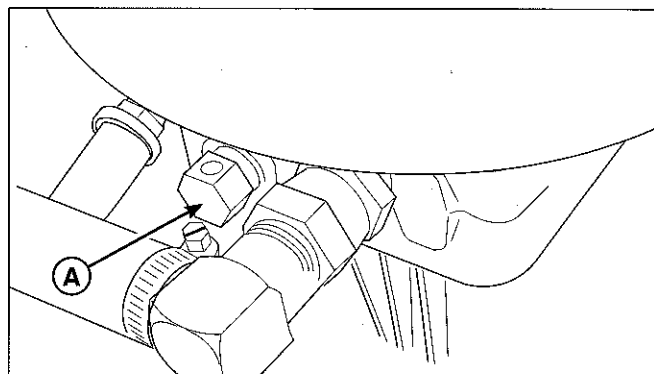

Figure 2. Hydraulic System By-Pass  
A. Hydraulic Release Valve (left-hand pump shown)

# Operation

## Zero-Turn Driving Practice

The lever controls of the Zero Turn rider are responsive, and learning to gain a smooth and efficient control of the rider's forward, reverse, and turning movements will take some practice.

Spending some time going through the maneuvers shown and becoming familiar with how the unit accelerates, travels, and steers — before you begin mowing — is absolutely essential to getting the most out of the Zero Turn rider.

**Locate a smooth, flat area of your lawn** — one with plenty of room to maneuver. (Clear the area of objects, people and animals before you begin.) Operate the unit at mid-throttle during this practice session (ALWAYS operate at full throttle when mowing), and turn slowly to prevent tire slippage and damage to your lawn.

We suggest you begin with the Smooth Travel procedure to the right, and then advance through the forward, reverse, and turning maneuvers.

You must release the parking brake prior to moving the control levers inward.

## Smooth Travel

The lever controls of the Zero Turn rider are responsive.

The BEST method of handling the ground speed control levers is in three steps — as shown in Figure 3.

**FIRST** place your hands onto the levers as shown.

**SECOND**, to go forward gradually push the levers forward with your palms.

**THIRD**, to speed up move the levers farther forward. To slow down smoothly, slowly move the levers toward neutral.

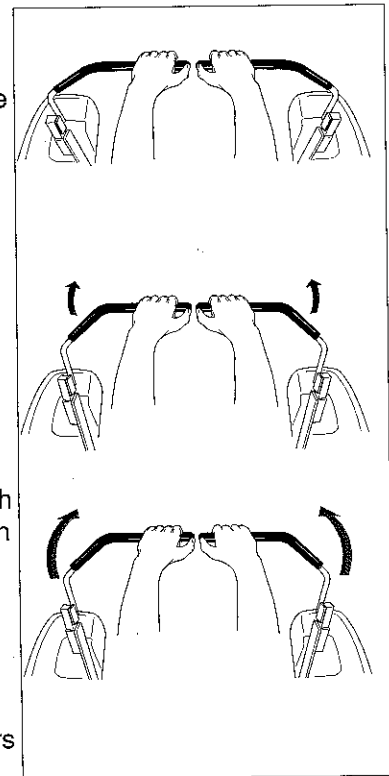

Figure 3. Move Control Levers Gradually

## BASIC DRIVING

### Forward Travel Practice

Gradually move both ground speed control levers — evenly FORWARD from neutral. Slow down and repeat.

*NOTE: Straight forward travel takes practice. If necessary, top speed can be balance-adjusted — see the Speed Balancing Adjustment in the Adjustments section near the back of this manual.*

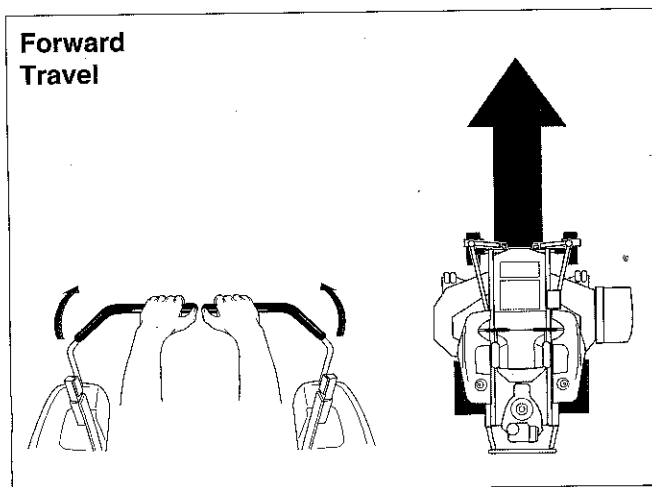

Figure 4. Forward Travel

### Reverse Travel Practice

LOOK DOWN & BEHIND, then gradually move both ground speed control levers evenly BACK from neutral. Slow down and repeat.

*NOTE: Practice backing up for several minutes before attempting to do so near objects. The rider turns sharply in reverse as well as forward, and backing up straight takes practice.*

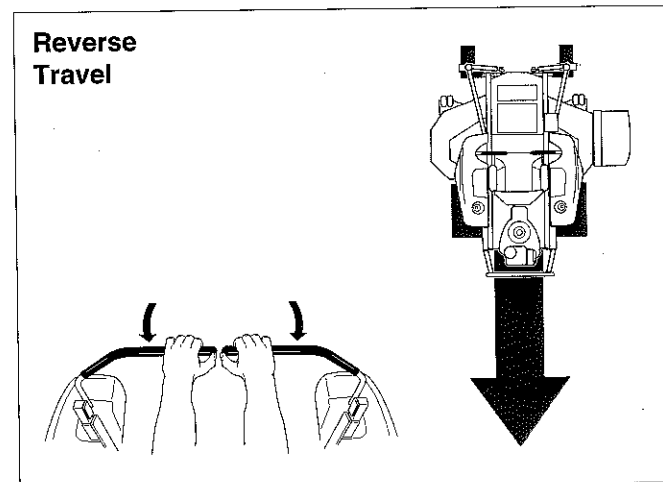

Figure 5. Reverse Travel

**Practice Turning Around a Corner**

While traveling forward allow one handle to gradually return back toward neutral. Repeat several times.

*NOTE: To prevent pivoting directly on the tire tread, it is best to keep both wheels going at least slightly forward.*

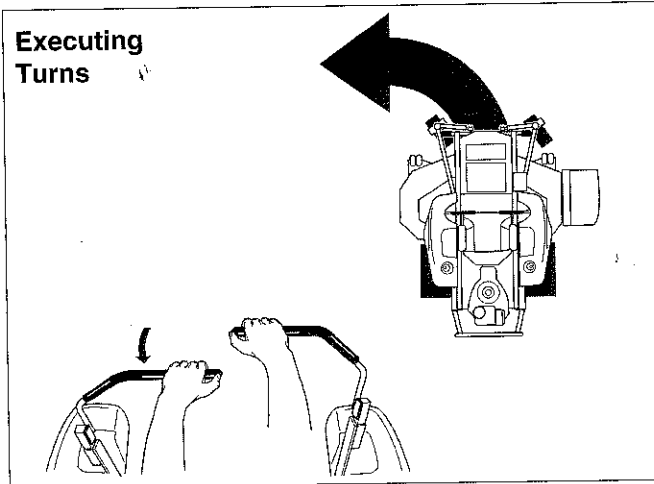

Figure 6. Turning Around a Corner

**Practice Turning In Place**

To turn in place, "Zero Turn," gradually move one ground speed control lever forward from neutral and one lever back from neutral simultaneously. Repeat several times.

*NOTE: Changing the amount each lever is pulled—forward or back, changes the "pivot point" you turn on.*

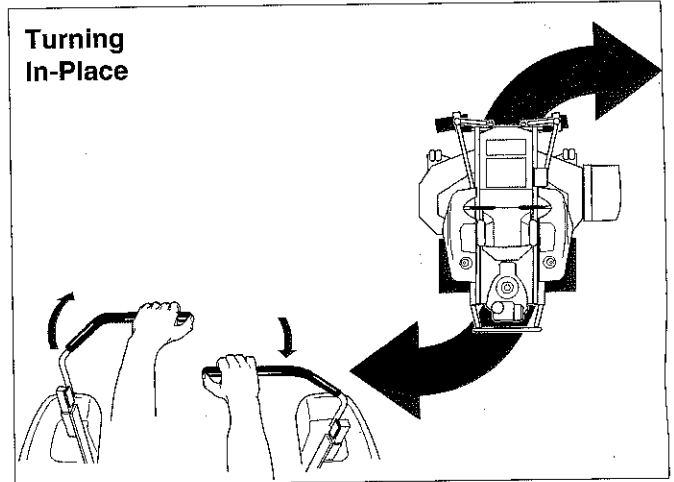

Figure 7. Turning in Place

**ADVANCED DRIVING**

**Executing an End-Of-Row Zero Turn**

Your Zero Turn Rider's unique ability to turn in place allows you to turn around at the end of a cutting row rather than having to stop and Y-turn before starting a new row.

For example, to execute a left end-of row zero turn:

1. Slow down at the end of the row.
2. Move the RIGHT ground speed control lever forward slightly while moving the LEFT ground speed control lever back to center and then slightly back from center.
3. Begin mowing forward again.

This technique turns the rider LEFT and slightly overlaps the row just cut—eliminating the need to back up and re-cut missed grass.

*As you become more familiar and experienced with operating the Zero Turn rider, you will learn more maneuvers that will make your mowing time easier and more enjoyable.*

**Remember, the more you practice, the better your control of the Zero Turn will be!**

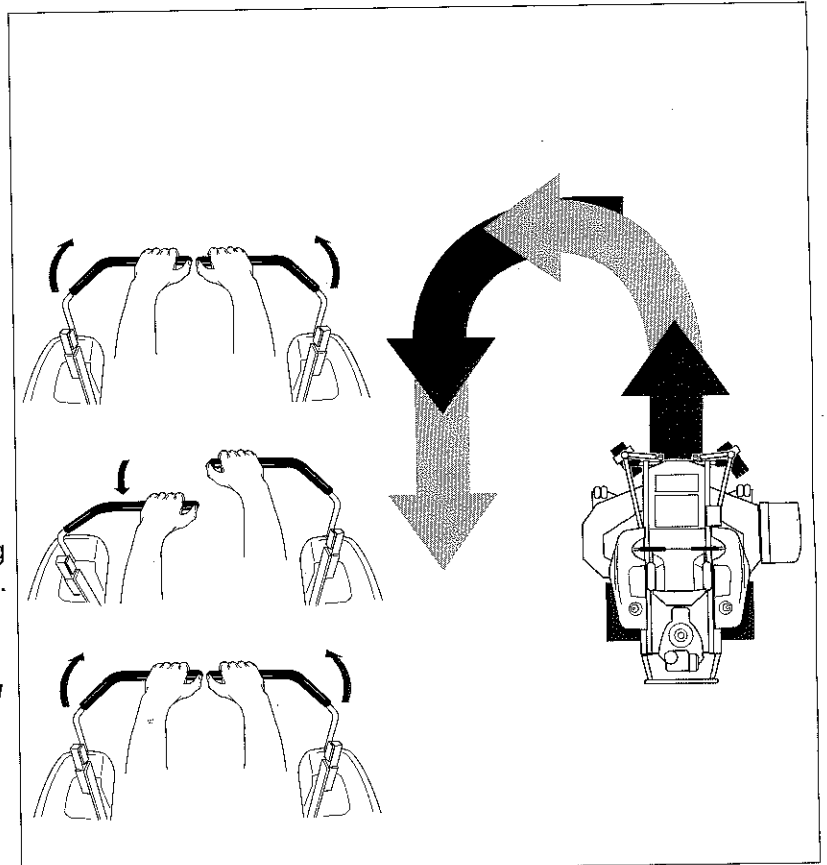
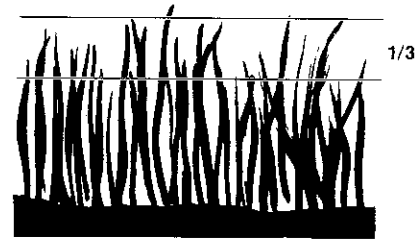

Figure 8. Executing an End-Of-Row Turn

## Mowing

1. Engage the parking brake. Make sure the PTO switch is disengaged, the motion control handles are locked in the NEUTRAL position and the operator is on the seat.
2. Start the engine (see STARTING THE ENGINE).
3. Set the mower cutting height.
4. Set the throttle to FULL.
5. Engage the PTO by pulling up on the PTO switch.
6. Begin mowing.
7. When finished, shut off the PTO.
8. Stop the engine (see STOPPING THE RIDER).



*Proper Cutting Height*

## Mowing Recommendations

Several factors can affect how well your machine cuts grass. Following proper mowing recommendations can improve the performance and life of your machine.

### Height of Grass

Often cutting height is a matter of personal preference. Typically, you should mow the grass when it is between three and five inches high.

The proper cutting height range for a specific lawn will depend upon several factors, including the type of grass, the amount of rainfall, the prevailing temperature, and the lawn's overall condition.

Cutting the grass too short causes weak, thin grass plants, which are easily damaged by dry periods and pests. Cutting too short is often more damaging than allowing the grass to be slightly higher.

Letting grass grow a bit longer—especially when it is hot and dry—reduces heat build-up, preserves needed moisture and protects the grass from heat damage and other problems. However, allowing grass to grow too high can cause thin turf and additional problems.

Cutting off too much at one time shocks the plant's growth system and weakens the grass plants. **A good rule of thumb is the 1/3 rule: to cut no more than one third of the grass height, and never more than 1 inch at a time.**

The amount of grass you are able to cut in one pass is also effected by the type of mowing system you are using (for example, broadcasting with side discharge decks can process a much larger volume of grass than mulching does).

### Tall Grass Requires Incremental Cutting

For extremely tall grass, set the cutting height at maximum for the first pass, and then reset it to the desired height and mow a second or third time.

Don't cover the grass surface with a heavy layer of clippings. Consider using a grass collection system and starting a compost pile.

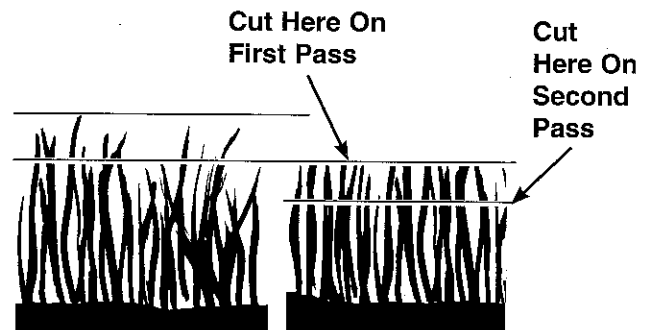

*Incremental Cutting*

## When and How Often to Mow

The time of day and condition of the grass greatly affect the results you'll get when mowing. For the best results, follow these guidelines:

1. Mow when the grass is between three and five inches high.
2. Mow with sharp blades. Short clippings of grass one inch or shorter decompose more quickly than longer blades. Sharp mower blades cut grass cleanly and efficiently, preventing frayed edges which harm the grass.
3. Mow at time of day when the grass is cool and dry. Late afternoon or early evening often provide these ideal mowing conditions.
4. Avoid mowing after rain or even heavy dew, and never mulch when the grass is wet (moist grass does not mulch well, and clumps beneath the mower deck).

## Mowing Patterns

Always start mowing on a smooth, level area.

The size and type of area to be mowed will determine the best mowing pattern to use. Obstructions such as trees, fences and buildings, and conditions such as slopes and grades must also be considered.

1. Cut long straight strips overlapping slightly.
2. Where possible, change patterns occasionally to eliminate matting, graining or a corrugated appearance.
3. For a truly professional cut, mow across the lawn in one direction, then recut the lawn by mowing perpendicular to the previous cut.

**Note: Always operate the engine at full throttle when mowing.**

If you hear the engine slowing down, you are mowing too fast—using a slower ground speed will improve the cutting efficiency of the blades and prevents many common cutting problems. Use an appropriate ground speed for the thickness and height of the grass you are cutting (3rd gear or slower for manual gear models). If you hear the engine slowing down you are mowing too fast, use a slower ground speed.

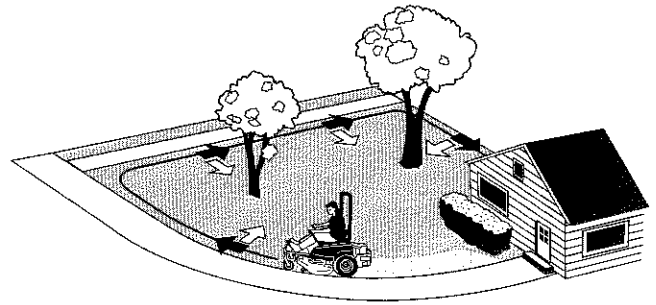

Where possible, make one or two passes around the outside of the area discharging the grass INTO the lawn to keep the cut grass off fences and walks.

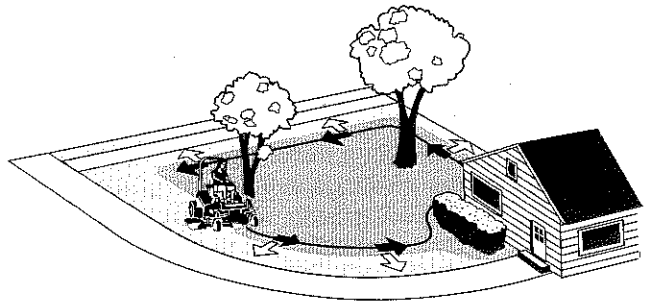

The remainder of the mowing should be done in the opposite direction so that the clippings are dispersed OUT onto the area of lawn previously cut.

## Mowing Methods

### Proper Broadcast Mowing

Broadcasting, or side-discharging, disperses fine clippings evenly over the entire lawn. Many golf courses use this method. Your mower has a deep dish deck to allow freer circulation of clippings so they are broadcast evenly over the lawn.

### ENGINE SPEED & GROUND SPEED FOR BROADCASTING

Always operate the engine at full throttle when mowing. If you hear the engine slowing down, you are mowing too fast—using a slower ground speed will improve the cutting efficiency of the blades and prevents many common cutting problems.

ALWAYS use an appropriate ground speed for the thickness and height of the grass you are cutting (3rd gear or slower for manual gear models). If you hear the engine slowing down you are mowing too fast, use a slower ground speed.

### HOW MUCH GRASS TO CUT OFF WHEN BROADCASTING

Mow when the grass is 3-5 inches long. Do not cut the grass shorter than 2 to 2-1/2 inches. Do not cut off more than 1 inch of grass in a single pass

# Operation

## Proper Mulching

Mulching consists of a mower deck which cuts and recuts clippings into tiny particles and which then blows them down INTO the lawn. These tiny particles decompose rapidly into by-products your lawn can use. **UNDER PROPER CONDITIONS**, your mulching mower will virtually eliminate noticeable clippings on the lawn surface.

**NOTE:** When mulching under heavy cutting conditions, a rumbling sound may be present and is normal.

## MULCHING REQUIRES EXCELLENT MOWING CONDITIONS

Mulching mowers cannot function properly if the grass is wet, or if the grass is simply too high to cut. Even more than normal mowing, mulching requires that the grass be dry and the appropriate amount is cut.

Do not use the mower as a mulching mower during the first two or three mowings in the spring. The long grass blades, quick growth, and often wetter conditions are more suitable for broadcasting (side-discharging) or grass bagging operation.

## ENGINE SPEED & GROUND SPEED FOR BROADCASTING

Use full engine throttle matched with a slow ground speed so that clippings will be finely cut. Ground speed while mulching should be **HALF** of the speed that would be used when broadcasting (side discharging) under similar conditions. Since mulching requires more horsepower than broadcasting, using a slower ground speed is vitally important for proper mulching operation.

## HOW MUCH GRASS TO MULCH

The best mulching action typically results from cutting only the top 1/2 inch to 3/4 inch of grass blade. This provides short clippings which decompose properly (much more quickly than longer clippings). The ideal cutting height will vary with climate, time of year, and quality of your lawn. We recommend that you experiment with both the cutting height and ground speed until you achieve the best cut. Start with a high cutting height and using progressively lower settings until you find a cutting height that is matched to your mowing conditions and preferences.

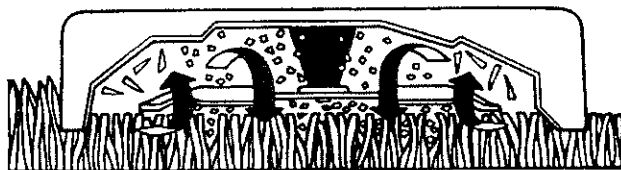

Mulching Action

## Attaching a Trailer

The maximum weight of a towed trailer should be less than 300 lbs (138kg). Secure the trailer with an appropriately sized clevis pin (A, Figure 9) and clip (B).

Excessive towed loads can cause loss of traction and loss of control on slopes. Reduce towed weight when operating on slopes. The surface being driven on greatly impacts traction and stability. Wet or slippery surfaces can greatly reduce traction and the ability to stop or turn. Carefully evaluate the surface conditions before operating the unit and trailer, and never operate on slopes greater than 10°. See **SLOPE OPERATION** and **TOWED EQUIPMENT** in the safety section of this manual for additional safety information.

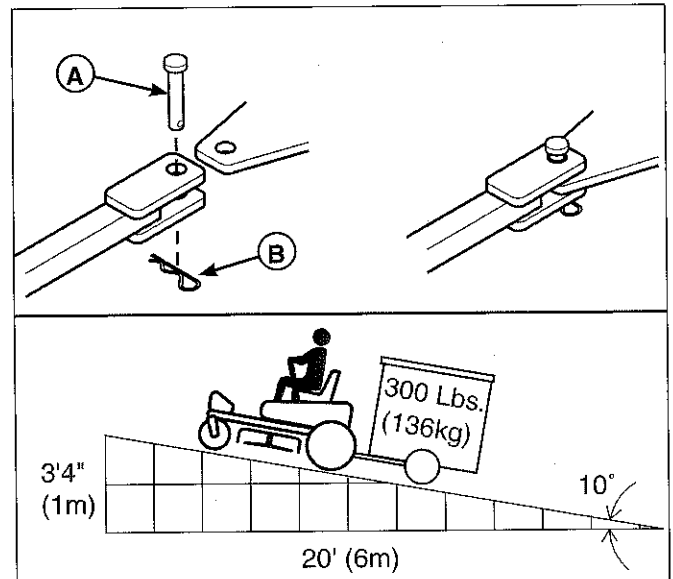

Figure 9. Trailer Weight Recommendations

- A. Clevis Pin
- B. Clip

## Raise & Lower the Roll Bar

### To lower the roll bar:

1. Pull the hair pin clips (A, Figure 10) out of the retainer pins (B).
2. Push or pull the top of the roll bar (C) forward against the rubber stops (D) and remove the retainer pins (B).
3. Lower the roll bar and reinstall the retainer pins and hair pin clips to secure the roll bar in the down position (see insert, Figure 10).

### To raise the roll bar:

1. Pull the hair pin clips (A) out of the retainer pins (B) and remove the retainer pins.
2. Raise the roll bar (C) until the rubber stops (D) contact the upright tubes.
3. Push or pull the top of the roll bar forward against the rubber stops and reinstall the retainer pins and hair pin clips to secure the roll bar in the raised position.

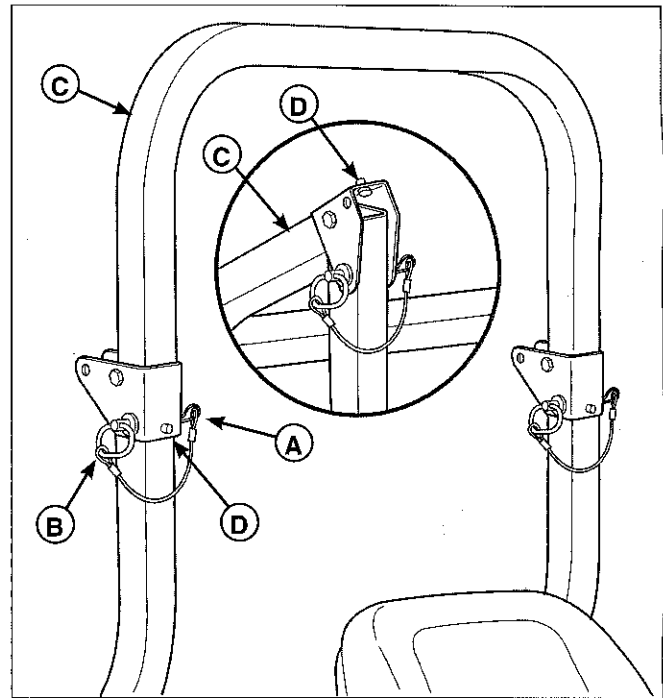

Figure 10. Raise & Lower the Roll Bar

- A. Hair Pin Clip
- B. Retainer Pin
- C. Roll Bar
- D. Rubber Stop

## **!** WARNING

**AVOID SERIOUS INJURY OR DEATH FROM ROLL OVER:**

**Keep roll bar in the raised position and use seat belt.**

**THERE IS NO ROLL OVER PROTECTION WHEN THE ROLL BAR IS DOWN**

**Lower the roll bar only when necessary and NEVER remove it.**

**Do NOT use seat belt when the roll bar is down.**

**Raise the roll bar as soon as clearance permits.**

**Do NOT jump off if mower tips.**

## Storage

### Temporary Storage (30 Days Or Less)

Remember, the fuel tank will still contain some gasoline, so never store the unit indoors or in any other area where fuel vapor could travel to any ignition source. Fuel vapor is also toxic if inhaled, so never store the unit in any structure used for human or animal habitation.

Here is a checklist of things to do when storing your unit temporarily or in between uses:

- Keep the unit in an area away from where children may come into contact with it. If there's any chance of unauthorized use, remove the spark plug (s) and put in a safe place. Be sure the spark plug opening is protected from foreign objects with a suitable cover.
- If the unit can't be stored on a reasonable level surface, chock the wheels.
- Clean all grass and dirt from the mower.

### Long Term Storage (Longer Than 30 Days)

Before you store your unit for the off-season, read the Maintenance and Storage instructions in the Safety Rules section, then perform the following steps:

1. Drain crankcase oil while engine is hot and refill with a grade of oil that will be required when unit is used again.
2. Prepare the mower deck for storage as follows:
  - a. Remove mower deck from the unit.
  - b. Clean underside of mower deck.
  - c. Coat all bare metal surfaces with paint or light coat of oil to prevent rusting.
3. Clean external surfaces and engine.
4. Prepare engine for storage. See engine owner's manual.
5. Clean any dirt or grass from cylinder head cooling fins, engine housing and air cleaner element.
6. Cover air cleaner and exhaust outlet tightly with plastic or other waterproof material to keep out moisture, dirt and insects.
7. Completely grease and oil unit as outlined in the Normal Care section.
8. Clean up unit and apply paint or rust preventative to any areas where paint is chipped or damaged.
9. Be sure the battery is filled to the proper level with water and is fully charged. Battery life will be increased if it is removed, put in a cool, dry place and fully charged about once a month. If battery is left in unit, disconnect the negative cable.

## WARNING

Never store the unit, with gasoline in engine or fuel tank, in a heated shelter or in enclosed, poorly ventilated enclosures. Gasoline fumes may reach an open flame, spark or pilot light (such as a furnace, water heater, clothes dryer, etc.) and cause an explosion.

Handle gasoline carefully. It is highly flammable and careless use could result in serious fire damage to your person or property. Drain fuel into an approved container outdoors away from open flame or sparks.

10. Drain fuel system completely or add a gasoline stabilizer to the fuel system. If you have chosen to use a fuel stabilizer and have not drained the fuel system, follow all safety instructions and storage precautions in this manual to prevent the possibility of fire from the ignition of gasoline fumes. Remember, gasoline fumes can travel to distant sources of ignition and ignite, causing risk of explosion and fire.

*NOTE: Gasoline, if permitted to stand unused for extended periods (30 days or more), may develop gummy deposits which can adversely affect the engine carburetor and cause engine malfunction. To avoid this condition, add a gasoline stabilizer to the fuel tank and run the engine a few minutes, or drain all fuel from the unit before placing it in storage.*

### Starting After Long Term Storage

Before starting the unit after it has been stored for a long period of time, perform the following steps.

1. Remove any blocks from under the unit.
2. Install the battery if it was removed.
3. Unplug the exhaust outlet and air cleaner.
4. Fill the fuel tank with fresh gasoline. See engine manual for recommendations.
5. See engine owner's manual and follow all instructions for preparing engine after storage.
6. Check crankcase oil level and add proper oil if necessary. If any condensation has developed during storage, drain crankcase oil and refill.
7. Inflate tires to proper pressure. Check fluid levels.
8. Start the engine and let it run slowly. DO NOT run at high speed immediately after starting. Be sure to run engine only outdoors or in well ventilated area.

## Maintenance

### Maintenance Schedule & Procedures

The following schedule should be followed for normal care of your rider and mower. You will need to keep a record of your operating time. Determining operating time is easily accomplished by observing the elapsed time recorded by the hour meter.

| <b>RIDER MAINTENANCE</b>                   |
|--|
| <b>Before Each Use</b>                     |
| Check Safety Interlock System              |
| Check Rider Brakes                         |
| Check Rider / Mower for loose hardware     |
| Check Hydraulic Oil Level                  |
| <b>Every 25 Hours</b>                      |
| Clean Deck & Check / Replace Mower Blades* |
| Initial Check / Adjustment of PTO Clutch   |
| Lubricate Rider & Mower*                   |
| Check Tire Pressure                        |
| <b>Every 100 Hours</b>                     |
| Check Mower Blade Stopping Time            |
| Check / Adjust PTO Clutch                  |
| Clean Battery & Cables                     |
| <b>Every 250 Hours</b>                     |
| Change Hydraulic Oil Filter*               |

| <b>ENGINE MAINTENANCE</b>                        |
|--|
| <b>Before Each Use</b>                           |
| Check Engine Oil Level / Engine Coolant Level    |
| <b>Every 25 Hours</b>                            |
| Check / Clean Cooling Fins & Intake*             |
| <b>Every 50 Hours</b>                            |
| Check / Clean Spark Arrester**                   |
| <b>Refer to Engine Owner's Operator's Manual</b> |
| Service Air Filter                               |
| Change Oil & Filter                              |
| Check / Replace Spark Plugs                      |
| Check / Replace Fuel Filter                      |

\* More often in hot (over 85° F: 30° C) weather or dusty operating conditions.

\*\* If equipped. Replace if damaged.

### Check Engine Oil Level

**Interval:** Before Each Use

Refer to the engine owners manual for dipstick and oil fill locations and specific engine oil check and fill procedures.

### Engine Maintenance

For engine maintenance schedules and procedures, please refer to the engine operator's manual.

# Regular Maintenance

## Check Tire Pressures

Tire pressure should be checked periodically, and maintained at the levels shown in the chart. Note that these pressures may differ slightly from the "Max Inflation" stamped on the side-wall of the tires. The pressures shown provide proper traction, improve cut quality, and extend tire life.

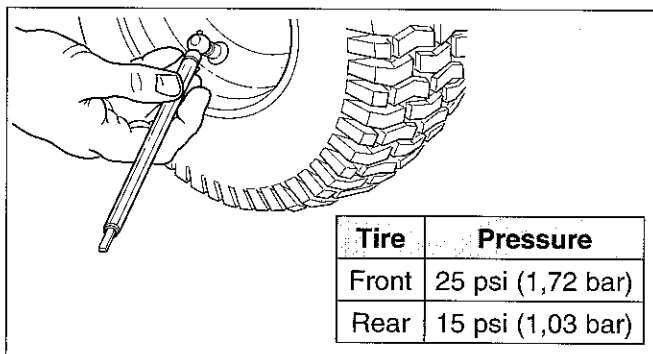

Figure 11. Checking Tire Pressure

## Checking / Adding Fuel

To add fuel:

1. Remove the fuel cap.
2. Fill the tank to the bottom of the filler neck. This will allow for fuel expansion.

*NOTE: Do not overfill. Refer to your engine manual for specific fuel recommendations.*

3. Install and hand tighten the fuel cap.
4. Repeat same process for opposite tank.

## Fuel Filter

**Carburated Models:** The fuel filter is located in the fuel line between fuel shut off valve and carburetor, near the fuel pump. **DFI Models:** The fuel filter is located in the fuel shut off valve and fuel pump, on the left side of the engine. If filter is dirty or clogged, replace as follows:

1. Shut off the fuel tank selection valve.
2. Disconnect the negative battery cable.
3. Place a container below the filter to catch spilled fuel.
4. Using a pliers, open and slide hose clamps from fuel filter.
5. Remove hoses from filter.
6. Install new filter in proper flow direction in fuel line.
7. Secure with hose clamps.
8. Reconnect the negative battery cable when finished.

## Change Oil & Filter

1. Warm engine by running for a few minutes. (Refer to the engine operator's manual for oil & filter replacement instructions.)
2. Place a small pan under the oil drain hose to catch the oil. Using the appropriate tools, remove the cap (B, Figure 12) from the oil drain hose (A) and drain the engine oil.
3. After draining, replace the cap and wipe up any spilled oil.
4. Place an absorbent shop cloth under the engine oil filter. Remove the engine oil filter and replace with a new one.
5. Remove the shop cloth and wipe up any spilled oil.

## ⚠ WARNING

Gasoline is highly flammable and must be handled with care. Never fill the tank when the engine is still hot from recent operation. Do not allow open flame, smoking or matches in the area. Avoid over-filling and wipe up any spills.

Do not remove fuel filter when engine is hot, as spilled gasoline may ignite. DO NOT spread hose clamps further than necessary. Ensure clamps grip hoses firmly over filter after installation.

⊘ Do not use gasoline containing METHANOL, gasohol containing more than 10% ethanol, gasoline additives, premium gasoline, or white gas because engine/fuel system damage could result.

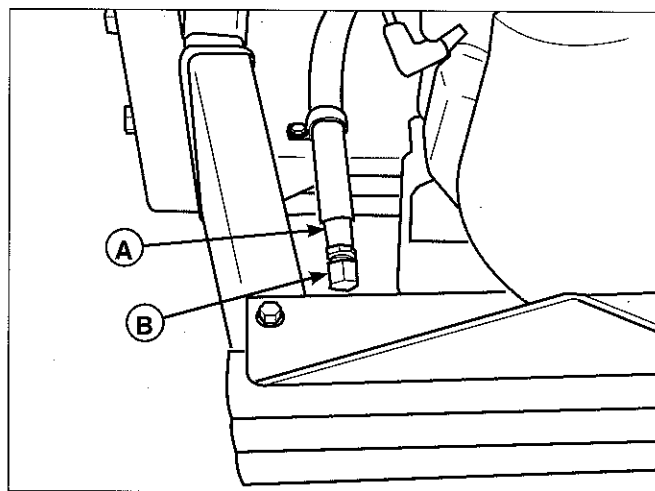

Figure 12. Engine Oil Drain  
A. Oil Drain Hose  
B. Cap

## Inspect Muffler and Spark Arrester

Inspect the muffler for cracks, corrosion, or other damage. Remove the spark arrester, if equipped, and inspect for damage or carbon blockage. If replacement parts are required, make sure to use only original equipment replacement parts.

## Check Hydraulic Oil Level

**NOTE:** Do not open the hydraulic reservoir unless oil is being added.

1. Lift up the seat plate to gain access to the oil reservoir compartment.
2. Look at the hydraulic oil reservoir (A, Figure 13) and observe the oil level. When cold, the oil level should be approximately 1/2" (1,3cm) below the MAX. HOT OIL LEVEL line. The oil level should never be above the MAX. HOT OIL LEVEL line.
3. If necessary, remove the reservoir cap (B, Figure 13) and add either Mobil 1, 15W-50 synthetic oil or Castrol Syntec 5W-50 oil. **DO NOT** use conventional oils. Make sure area around the fill neck of the reservoir is free of dust, dirt, or other debris.

## **⚠ WARNING**

Replacement parts must be the same and installed in the same position as the original parts or fire could result.

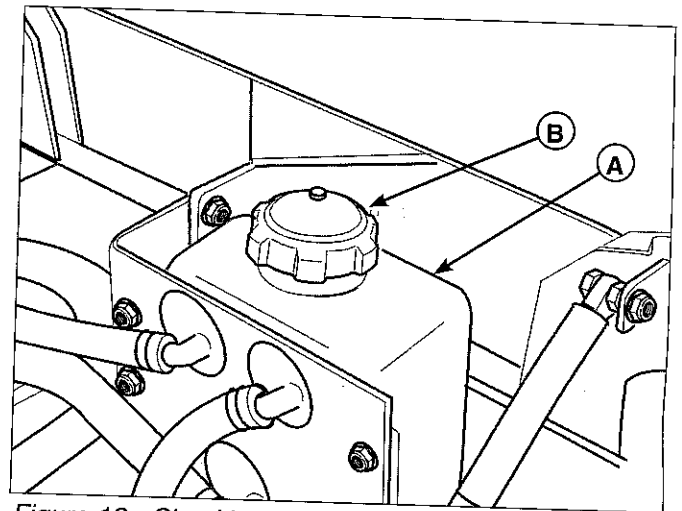

Figure 13. Checking Hydraulic Oil Level  
A. Hydraulic Oil Reservoir  
B. Reservoir Cap

## Hydraulic Oil Filter Change

**Change Interval:** Every 500 Hours

**Filter Part Number:** 5021357

**NOTE:** Removing the oil filter from the filter base will drain the oil reservoir. Have a suitable container ready to catch any spilled oil. Ferris recommends this be a dealer-only service item.

1. Locate the hydraulic oil filter (A, Figure 14) behind the oil reservoir.
2. Fill the new filter with oil. Lubricate the new filter seal with a few drops of oil.
3. Remove the oil filter and quickly thread the new filter onto the filter base until the gasket makes contact, then tighten 3/4 of a turn more.
4. Refill reservoir with fresh oil to replace any oil lost during filter change.
5. Raise the rear of the unit and secure with jackstands. Chock the front wheels to prevent the unit from rolling. Run the unit for several minutes to purge any air from the hydraulic system and check the hydraulic oil level.

**IMPORTANT NOTE:** Use caution after changing the filter; air in the hydraulic system may affect the responsiveness of the control levers. Repeat step 5 until the air is out of the system.

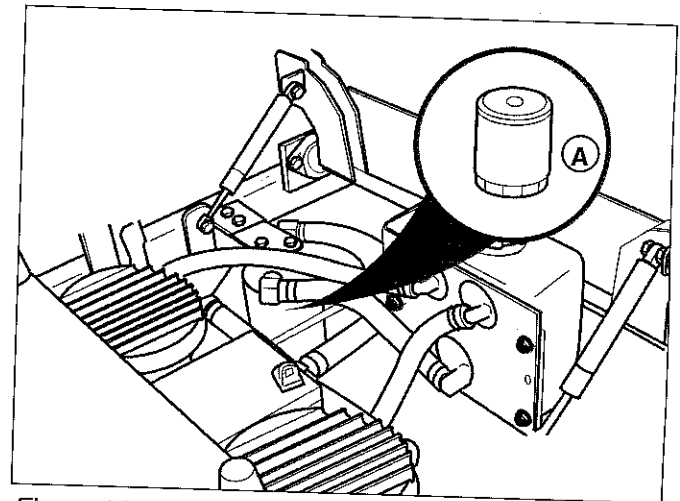

Figure 14. Hydraulic Oil Filter Location  
A. Oil Filter

## Regular Maintenance

### Cooling System (Liquid Cooled Models Only)

#### Check Engine Coolant Level

The engine coolant level and quality should be checked before each use, when the engine is cool and off.

The cooling system is a closed type. Never open the radiator cap. Doing so may induce air into the cooling system and may cause overheating.

1. Check the coolant level only at the overflow reservoir (A). The coolant level should be between the "H" and "L" marks.
2. If the coolant level is insufficient, remove the cap (B) from the reservoir and add coolant to the "H" mark.
3. Reinstall the cap.

*NOTE: Proper coolant mix is a 50/50 mixture of ethylene glycol and distilled water. See engine owners manual for engine coolant specifications.*

#### Change Engine Coolant

See engine owners manual for specific engine coolant change procedures.

#### Clean Radiator & Screen

Clean the radiator and screen before each use, or as required (depending on conditions) to allow proper air-flow through the radiator.

1. To remove the radiator screen, lift the seat.
2. Release radiator screen latch (C), slide towards the left hand side of the machine. Lift screen enough to clear radiator cap and slide out the front.
3. Flush the screen with water or blow clean with air. Flush the radiator core with water or blow clean with air. See engine owners manual for proper radiator cleaning procedures.
4. To reinstall the radiator screen, reverse removal process.

### **!** WARNING

#### PRESSURIZED SYSTEM

Hot coolant can cause serious burns. Never open the radiator cap. Wait until the engine is cool before checking the coolant level or removing the reservoir cap.

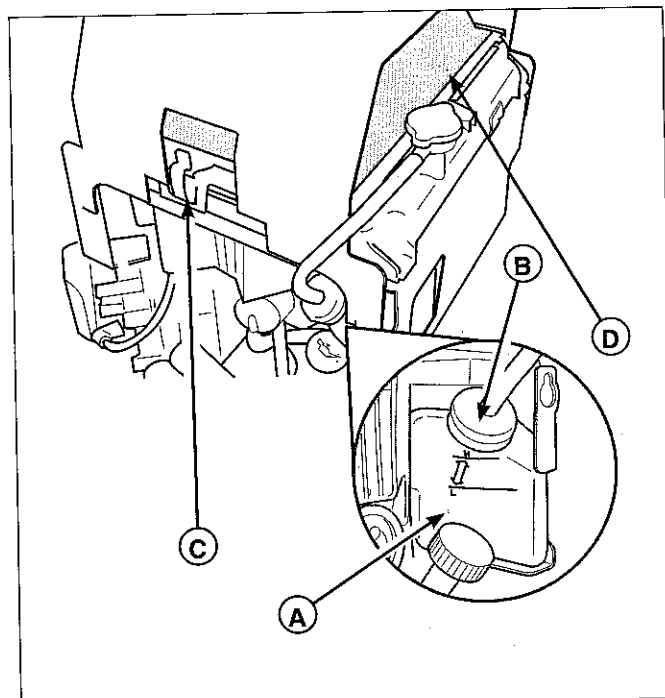

Figure 15. Radiator, Screen & Overflow Bottle

- A. Overflow Reservoir
- B. Reservoir Cap
- C. Radiator Screen Latch
- D. Radiator Screen

## Lubrication

Lubricate the unit at the locations shown in Figures 16 through 19 as well as the following lubrication points.

### Grease:



- front caster wheel axles & yokes
- deck lift pivot blocks
- mower deck spindles
- mower deck idler arm

Use grease fittings when present. Disassemble parts to apply grease to moving parts when grease fittings are not installed.

Not all greases are compatible. Ferris Red Grease (p/n 5022285) is recommended, automotive-type high-temperature, lithium grease may be used when this is not available.

### Oil:



- control handle pivots
- seat plate pivots
- deck lift pivots
- discharge chute hinge

Generally, all moving metal parts should be oiled where contact is made with other parts. Keep oil and grease off belts and pulleys. Remember to wipe fittings and surfaces clean both before and after lubrication.

### Lubricating the Front Casters

**NOTE:** Casters should be lubricated annually.

1. Remove the 1/4-28 bolt (A, Figure 19) screwed into the caster and install a 1/4-28 grease fitting.
2. Grease the front caster.
3. Remove the 1/4-28 grease fitting and reinstall the 1/4-28 bolt.
4. Repeat the process for the other side of the machine.

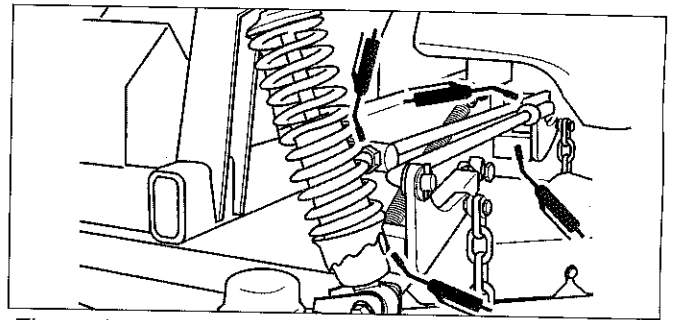

Figure 16. Deck Lift Linkage Pivots

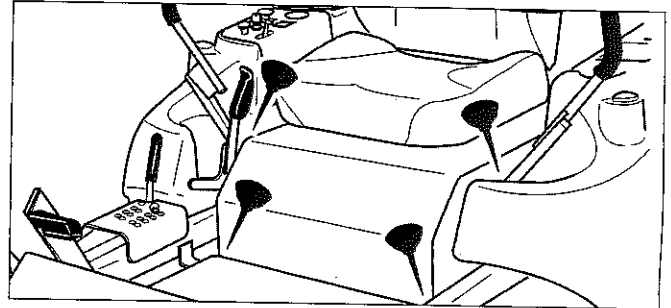

Figure 17. Control Handle Pivots

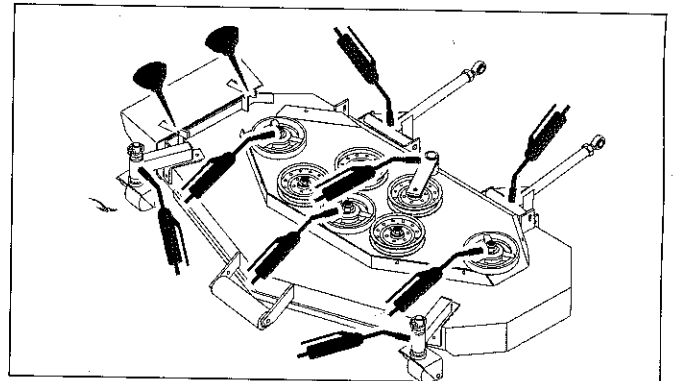

Figure 18. Deck Lubrication

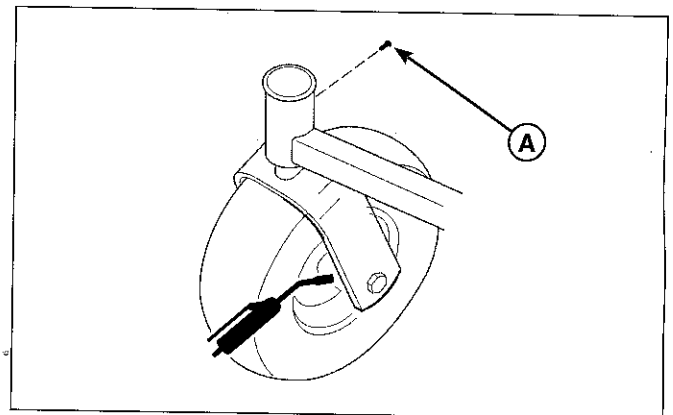

Figure 19. Front Caster & Wheel  
A. 1/4-28 Bolt

# Regular Maintenance

## Battery Maintenance

### Cleaning the Battery and Cables

1. Disconnect the cables from the battery, negative cable first (B, Figure 20).
2. Clean the battery terminals and cable ends with a wire brush until shiny.
3. Reinstall the battery and reattach the battery cables, positive cable first (A)
4. Coat the cable ends and battery terminals with petroleum jelly or non-conducting grease.

### **⚠ WARNING**

Be careful when handling the battery. Avoid spilling electrolyte. Keep flames and sparks away from the battery.

When removing or installing battery cables, disconnect the negative cable **FIRST** and reconnect it **LAST**. If not done in this order, the positive terminal can be shorted to the frame by a tool.

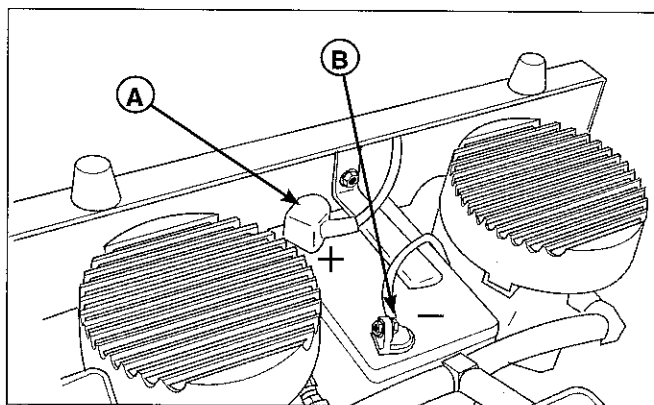

Figure 20. Battery Compartment  
A. Positive (+) Cable & Terminal  
B. Negative (-) Cable & Terminal

## Anti-Scalp Deck Casters

The anti-scalp deck casters (A, Figure 21) will aid in preventing the mower deck from scalping or gouging the turf while mowing or turning.

### 72" Models (S/N: 2014714094 & Below):

The casters can be adjusted in 1/2" (1,3 cm) increments with the spacers (B). The desired position is just below the leading edge of the deck.

**IMPORTANT NOTE:** These casters are not intended to be in contact with the ground at all times. If you are mowing at a low cut height, adjust the casters up to prevent the casters from carrying the weight of the deck.

### 61" Models (All) & 72" Models (S/N:2014714095 & Above):

These casters are not adjustable.

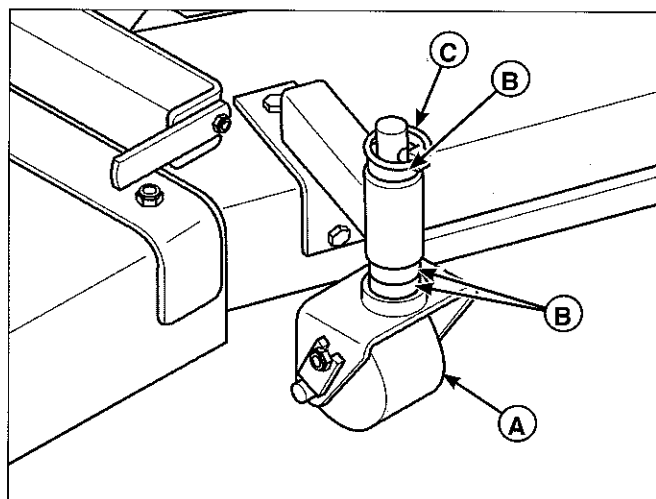

Figure 21. Anti-Scalp Deck Casters  
A. Deck Caster  
B. Spacer  
C. Lynch Pin

## Servicing the Mower Blades

### Removing the Mower Blade

#### **CAUTION**

Avoid injury. Mower blades are sharp.

- Always wear gloves when handling mower blades or working near blades.

1. To remove the mower blade, wedge a wooden block between the mower blade and the mower deck housing to keep the blade from turning and remove the mower blade mounting bolt with a 15/16" wrench (Figure 22).

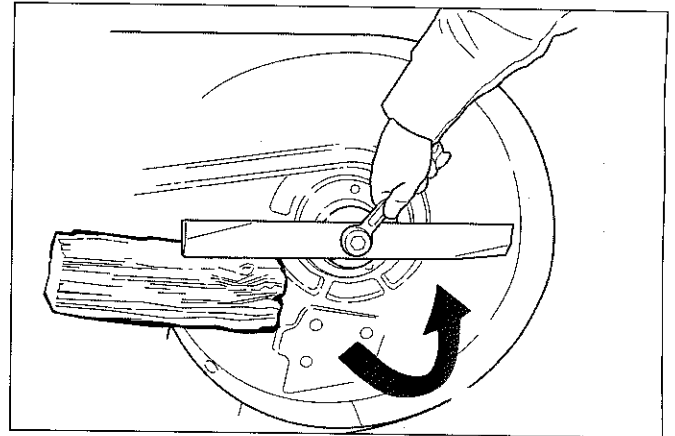

Figure 22. Loosening the Mower Blade for Removal

### Inspecting the Mower Blade

#### **DANGER**

Avoid injury. A worn or damaged blade can break, and a piece of the mower blade could be thrown into the operator's or bystander's area, resulting in serious personal injury or death.

- Inspect the mower blade every 25 hours or at least once a year.
- If the mower blade hits a solid object, stop the engine immediately and inspect the mower blade.
- Never weld or straighten bent mower blades.

1. Remove the mower blade from the unit.
2. Inspect the mower blade (Figures 23 & 24). Discard the mower blade if it has any of the below conditions:
  - A.) Has more than .5" (12,7 mm) of the mower blade metal removed from previous sharpening or wear (D, Figure 23).
  - B.) The air lifts are excessively eroded (B & C, Figure 24) and the notch (C) is .25" (6,35 mm) deep or greater.
  - C.) Mower blade is bent or broken.
3. If the cutting edges are not sharp or have nicks, sharpen the blades. See SHARPENING THE MOWER BLADES.

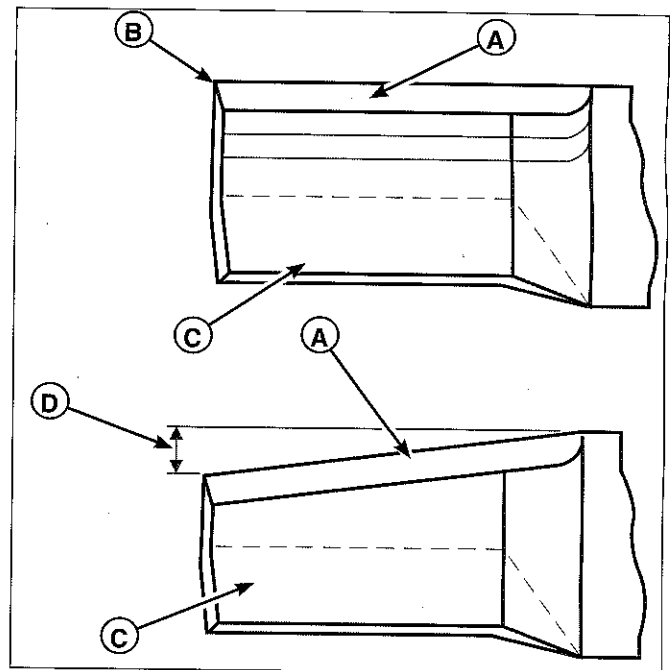

Figure 23. Inspecting the Mower Blade Tips

- A. Mower Blade Cutting Edge
- B. Square Corner
- C. Air Lift
- D. Wear Measurement - DISCARD Mower Blade If greater than .5" (12,7 mm)

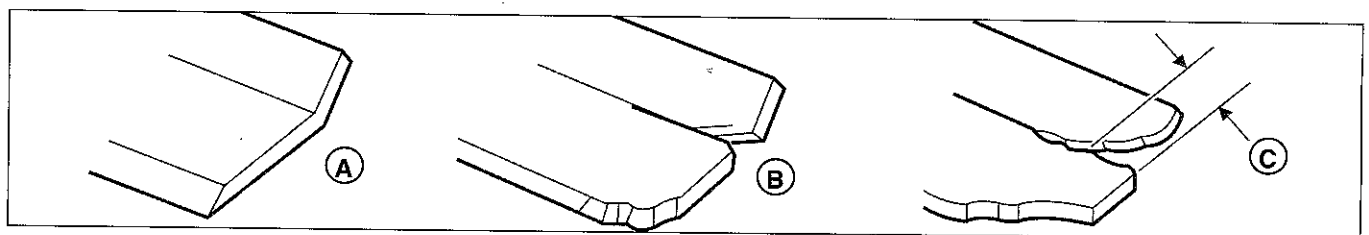

Figure 24. Inspecting the Mower Blade Air Lifts

- A. New Mower Blade
- B. Mower Blade at Wear Limit (A notch begins to form)
- C. Mower Blade in Dangerous Condition (Notch measures .25" (6,35 mm) or greater DO NOT USE. Replace with new mower blade.)

# Regular Maintenance

## Sharpening the Mower Blades

### **CAUTION**

Avoid injury. Mower blades are sharp.

- Always wear gloves when handling mower blades or working near blades.
- Always wear safety eye protection when grinding

1. Sharpen the mower blade with a grinder, hand file, or electric blade sharpening.
2. Sharpen the mower blade by removing an equal amount of material from each end of the mower blade.
3. Keep the original bevel (A, Figure 25) when grinding. Do NOT change the mower blade bevel.
4. The mower blade should have a maximum 1/64" (0,40 mm) cutting edge (B) or less.
5. Balance the mower blade before installing.

## Balancing the Mower Blades

### **CAUTION**

Avoid injury. Keep mower blades balanced.

- An unbalanced mower blade can create excessive vibration and damage the unit or cause mower blade failure.

1. Clean the mower blade to remove any dried grass or other debris.
2. See Figure 26. Put the mower blade on a nail in a vise and turn the blade to the horizontal position.
3. Check the balance of the mower blade. If either end of the mower blade moves downward, sharpen the heavy end until the mower blade is balanced. See SHARPENING THE MOWER BLADES for proper sharpening instructions.
4. Repeat the process until the mower blade remains in the horizontal position.

## Reinstalling the Mower Blades

1. Reinstall each mower blade with the air lifts pointing up towards the mower deck as shown in Figure 27. Secure with the mower blade mounting bolt and flat washer (A & B, Figure 27).
2. Wedge a wooden block between the mower blade and the mower deck housing to keep the mower blade from turning and torque to 70 ft. lbs (94 Nm).

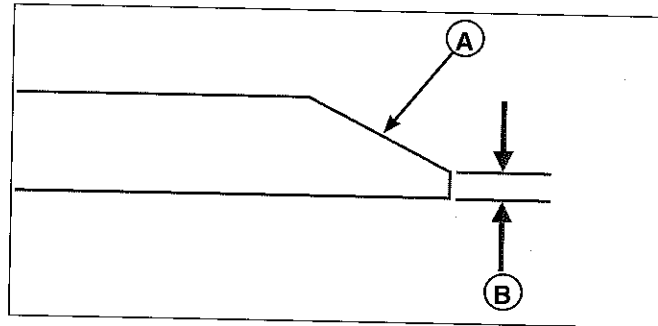

Figure 25. Sharpening the Mower Blade

- A. Mower Blade Bevel
- B. Mower Blade Cutting Edge

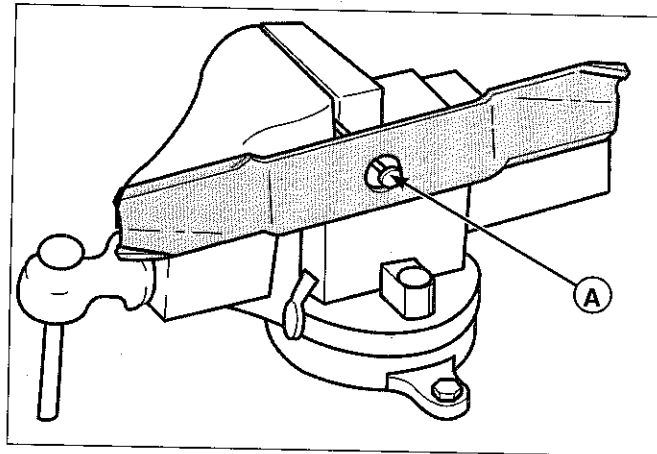

Figure 26. Balancing the Mower Blade

- A. Nail

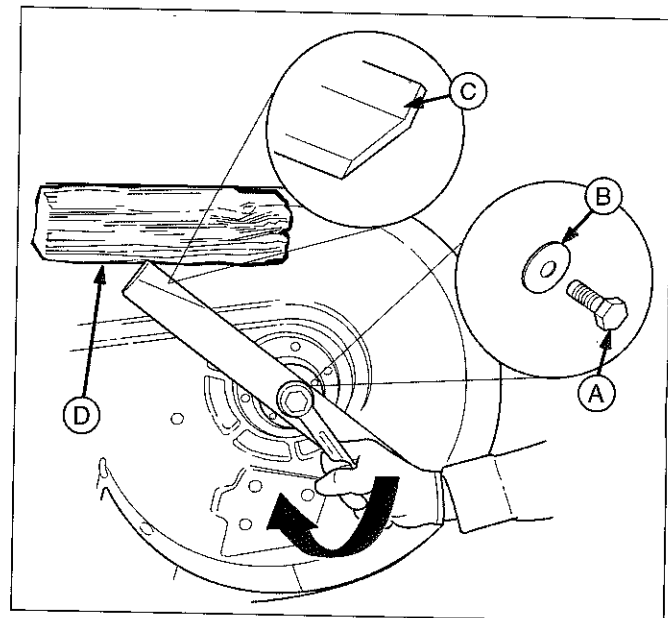

Figure 27. Tightening the Mower Blade for Installation

- A. Mower Blade Mounting Bolt
- B. Flat Washer
- C. Mower Blade Air Lift (Points Up For Installation)
- D. 4 X 4 Wooden Block

## Troubleshooting

While normal care and regular maintenance will extend the life of your equipment, prolonged or constant use may eventually require that service be performed to allow it to continue operating properly.

The troubleshooting guide below lists the most common problems, their causes and remedies.

See the information on the following pages for instructions on how to perform most of these minor adjustments and service repairs yourself. If you prefer, all of these procedures can be performed for you by your local authorized dealer.

### WARNING

To avoid serious injury, perform maintenance on the tractor or mower only when the engine is stopped and the parking brake engaged.

Always remove the ignition key, disconnect the spark plug wire and fasten it away from the plug before beginning the maintenance, to prevent accidental starting of the engine.

## TROUBLESHOOTING THE RIDER

| PROBLEM  | CAUSE  | REMEDY  |
|--|--|---|
| <b>Engine will not turnover or start.</b>                  | <ol style="list-style-type: none"> <li>1. Parking brake not engaged.</li> <li>2. PTO (electric clutch) switch in ON position.</li> <li>3. Out of fuel.</li> <li>4. Engine flooded.</li> <li>5. Fuse blown.</li> <li>6. Battery terminals require cleaning.</li> <li>7. Battery discharged or dead.</li> <li>8. Wiring loose or broken.</li> <li>9. Solenoid or starter motor faulty.</li> <li>10. Safety interlock switch faulty.</li> <li>11. Spark plug(s) faulty, fouled or incorrectly gapped.</li> <li>12. Water in fuel.</li> <li>13. Gas is old or stale.</li> <li>14. Malfunction in DFI system</li> </ol> | <ol style="list-style-type: none"> <li>1. Engage parking brake.</li> <li>2. Place in OFF position.</li> <li>3. If engine is hot, allow it to cool, then refill the fuel tank.</li> <li>4. <b>Carburated Models:</b> Move throttle control out of CHOKE position. <b>DFI Models:</b> See authorized dealer.</li> <li>5. Replace fuse.</li> <li>6. Clean the battery terminals</li> <li>7. Recharge or replace.</li> <li>8. Visually check wiring &amp; replace broken or frayed wires. Tighten loose connections.</li> <li>9. Repair or replace. See authorized dealer</li> <li>10. Replace as needed. See authorized service dealer.</li> <li>11. Clean and gap or replace. See engine manual.</li> <li>12. Drain fuel &amp; refill with fresh fuel.</li> <li>13. Drain fuel &amp; replace with fresh fuel.</li> <li>14. See authorized service dealer</li> </ol> |
| <b>Engine starts hard or runs poorly.</b>                  | <ol style="list-style-type: none"> <li>1. Fuel mixture too rich.</li> <li>2. Spark plug faulty, fouled, or incorrectly gapped.</li> </ol>  | <ol style="list-style-type: none"> <li>1. Clean air filter.<br/><b>Carburated Models:</b> Check choke adjustment.<br/><b>DFI Models:</b> See authorized service dealer.</li> <li>2. Clean and gap or replace. (See engine manual.)</li> </ol>   |
| <b>Engine knocks.</b>                                      | <ol style="list-style-type: none"> <li>1. Low oil level.</li> <li>2. Using wrong grade oil.</li> </ol>   | <ol style="list-style-type: none"> <li>1. Check/add oil as required.</li> <li>2. See engine manual.</li> </ol>  |
| <b>Excessive oil consumption.</b>                          | <ol style="list-style-type: none"> <li>1. Engine running too hot.</li> <li>2. Using wrong weight oil.</li> <li>3. Too much oil in crankcase.</li> </ol>  | <ol style="list-style-type: none"> <li>1. Clean engine fins, blower screen and air cleaner.</li> <li>2. See engine manual.</li> <li>3. Drain excess oil.</li> </ol>   |
| <b>Engine exhaust is black.</b>                            | <ol style="list-style-type: none"> <li>1. Dirty air filter.</li> <li>2. Engine choke control is in closed position.</li> </ol>   | <ol style="list-style-type: none"> <li>1. Replace air filter. See engine manual.</li> <li>2. Open choke control.</li> </ol>   |
| <b>Malfunction Indicator Lamp is flashing (DFI Models)</b> | <ol style="list-style-type: none"> <li>1. Problem with the DFI system.</li> </ol>  | <ol style="list-style-type: none"> <li>1. See your authorized service dealer.</li> </ol>  |

# Troubleshooting, Adjustment & Service

## RIDER TROUBLESHOOTING CONTINUED.

| PROBLEM                                | CAUSE  | REMEDY  |
|--|--|---|
| Engine runs, but rider will not drive. | <ol style="list-style-type: none"> <li>1. Hydraulic release valve(s) in "open" position.</li> <li>2. Belt is broken.</li> <li>3. Drive belt slips.</li> <li>4. Brake is not fully released.</li> </ol> | <ol style="list-style-type: none"> <li>1. Turn valve(s) clockwise to close.</li> <li>2. See Drive Belt Replacement.</li> <li>3. See problem and cause below.</li> <li>4. See authorized service dealer</li> </ol> |
| Rider drive belt slips.                | <ol style="list-style-type: none"> <li>1. Pulleys or belt greasy or oily.</li> <li>2. Belt stretched or worn.</li> </ol>   | <ol style="list-style-type: none"> <li>1. Clean as required.</li> <li>2. Replace belt.</li> </ol>   |
| Brake will not hold.                   | <ol style="list-style-type: none"> <li>1. Brake is incorrectly adjusted.</li> <li>2. Brake caliper pads worn.</li> </ol>   | <ol style="list-style-type: none"> <li>1. See Brake Adjustment.</li> <li>2. Replace with new brake pads.</li> </ol>   |
| Rider steers or handles poorly.        | <ol style="list-style-type: none"> <li>1. Steering linkage is loose.</li> <li>2. Improper tire inflation.</li> </ol>   | <ol style="list-style-type: none"> <li>1. Check and tighten any loose connections.</li> <li>2. See Regular Maintenance Section.</li> </ol>  |

## TROUBLESHOOTING THE MOWER

| PROBLEM                                   | CAUSE  | REMEDY  |
|---|--|---|
| Mower will not raise.                     | <ol style="list-style-type: none"> <li>1. Lift linkage not properly attached or damaged.</li> </ol>  | <ol style="list-style-type: none"> <li>1. See authorized service dealer for repair.</li> </ol>  |
| Engine stalls easily with mower engaged.  | <ol style="list-style-type: none"> <li>1. Engine speed too slow.</li> <li>2. Ground speed too fast.</li> <li>3. Cutting height set too low.</li> <li>4. Discharge chute jamming with cut grass.</li> </ol>                       | <ol style="list-style-type: none"> <li>1. Set to full throttle.</li> <li>2. Decrease Ground Speed.</li> <li>3. Cut tall grass at maximum cutting height during first pass.</li> <li>4. Cut grass with discharge pointing toward previously cut area.</li> </ol> |
| Excessive mower vibration.                | <ol style="list-style-type: none"> <li>1. Blade mounting bolts are loose.</li> <li>2. Mower blades, arbors, or pulleys are bent.</li> <li>3. Mower blades are out of balance.</li> <li>4. Belt installed incorrectly.</li> </ol> | <ol style="list-style-type: none"> <li>1. Tighten to 70 ft.lbs. (94 N.m.).</li> <li>2. Check and replace as necessary.</li> <li>3. Remove, sharpen, and balance blades. See Maintenance Section.</li> <li>4. Reinstall Correctly.</li> </ol>                    |
| Excessive belt wear or breakage.          | <ol style="list-style-type: none"> <li>1. Bent or rough pulleys.</li> <li>2. Using incorrect belt.</li> </ol>  | <ol style="list-style-type: none"> <li>1. Repair or replace.</li> <li>2. Replace with correct belt.</li> </ol>  |
| Mower drive belt slips or fails to drive. | <ol style="list-style-type: none"> <li>1. Idler pulley spring broken or not properly attached.</li> <li>2. Mower drive belt broken.</li> </ol>   | <ol style="list-style-type: none"> <li>1. Repair or replace as needed.</li> <li>2. Replace drive belt.</li> </ol>   |

## TROUBLESHOOTING COMMON CUTTING PROBLEMS

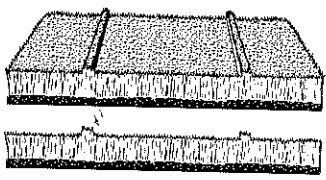
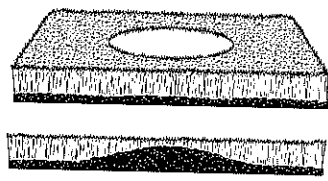
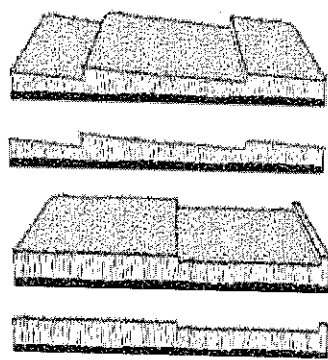
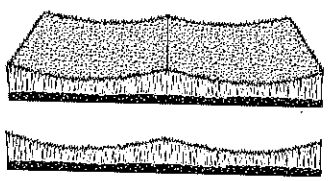
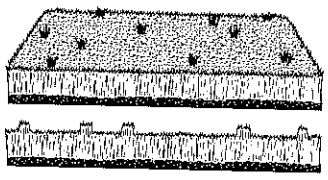
| PROBLEM   | CAUSE  | REMEDY  |
|---|--|---|
| <p><b>Streaking</b></p>          | <ol style="list-style-type: none"> <li>1. Blades are not sharp.</li> <li>2. Blades are worn down too far.</li> <li>3. Engine speed is too slow.</li> <li>4. Ground speed is too fast.</li> <li>5. Deck is plugged with grass.</li> <li>6. Not overlapping cutting rows enough.</li> <li>7. Not overlapping enough when turning.</li> </ol>   | <ol style="list-style-type: none"> <li>1. Sharpen your blades.</li> <li>2. Replace your blades.</li> <li>3. Always mow at FULL throttle.</li> <li>4. Slow down.</li> <li>5. Clean out the mower.</li> <li>6. Overlap you cutting rows.</li> <li>7. When turning your effective cutting width decreases—overlap more when turning.</li> </ol>                      |
| <p><b>Scalping</b></p>           | <ol style="list-style-type: none"> <li>1. Lawn is uneven or bumpy.</li> <li>2. Mower deck cutting height is set too low.</li> <li>3. Ground speed is too fast.</li> <li>4. Deck is not levelled correctly.</li> <li>5. Tire pressure is low or uneven.</li> </ol>  | <ol style="list-style-type: none"> <li>1. Roll or level the lawn.</li> <li>2. Raise the cutting height.</li> <li>3. Slow down.</li> <li>4. Correctly level the deck.</li> <li>5. Check and inflate the tires.</li> </ol>  |
| <p><b>Stepped Cutting.</b></p>  | <ol style="list-style-type: none"> <li>1. Deck is not leveled correctly.</li> <li>2. Tires are not properly inflated.</li> <li>3. Blades are damaged.</li> <li>4. Deck shell is damaged.</li> <li>5. Mower spindle is bent or loose.</li> <li>6. Blades are installed incorrectly.</li> </ol>  | <ol style="list-style-type: none"> <li>1. Level the deck correctly.</li> <li>2. Check and inflate the tires.</li> <li>3. Replace the blades.</li> <li>4. Repair or replace the deck.</li> <li>5. Repair or replace the spindle.</li> <li>6. Reinstall the blades correctly.</li> </ol>  |
| <p><b>Uneven Cutting</b></p>   | <ol style="list-style-type: none"> <li>1. Deck is not leveled correctly.</li> <li>2. Blades are dull or worn.</li> <li>3. Blades are damaged.</li> <li>4. Deck is clogged with grass clippings.</li> <li>5. Deck shell is damaged.</li> <li>6. Mower spindle is bent or loose.</li> <li>7. Blades are installed incorrectly.</li> <li>8. Tires are not properly inflated.</li> </ol> | <ol style="list-style-type: none"> <li>1. Level the deck correctly.</li> <li>2. Sharpen or replace the blades.</li> <li>3. Replace the blades.</li> <li>4. Clean out the deck.</li> <li>5. Repair or replace the deck.</li> <li>6. Repair or replace the spindle.</li> <li>7. Reinstall the blades correctly.</li> <li>8. Check and inflate the tires.</li> </ol> |
| <p><b>Stingers</b></p>         | <ol style="list-style-type: none"> <li>1. Blades are not sharp or nicked.</li> <li>2. Blades are worn down too far.</li> <li>3. Engine speed is too low.</li> <li>4. Ground speed is too fast.</li> <li>5. Deck is plugged with grass.</li> </ol>  | <ol style="list-style-type: none"> <li>1. Sharpen your blades.</li> <li>2. Replace your blades.</li> <li>3. Always mow at full throttle.</li> <li>4. Slow down.</li> <li>5. Clean out the mower.</li> </ol>   |

# Troubleshooting, Adjustment & Service

## Seat Adjustment

See Figure 28. The seat can be adjusted forward and back. Move the lever to the left, position the seat as desired, and release the lever to lock the seat into position.

## Seat Adjustment (Suspension Seat)

See Figure 26. In addition to the forward and backward seat adjustment, models equipped with a suspension seat can be adjusted for lumbar support, suspension and back angle.

### Forward and Backward Adjustment:

Move the forward / backward seat adjustment lever (A, Figure 29) away from the seat, position the seat as desired, and release the lever to lock the seat into position.

### Lumbar Adjustment:

Turn the lumbar adjustment knob (B) until the desired amount of lumbar is achieved.

### Back Angle Adjustment:

Turn the back angle adjustment knob (C) until the desired amount of back angle is achieved.

### Suspension Adjustment:

Turn the suspension adjustment knob (D) until the display scale has a reading that matches the weight of the operator.

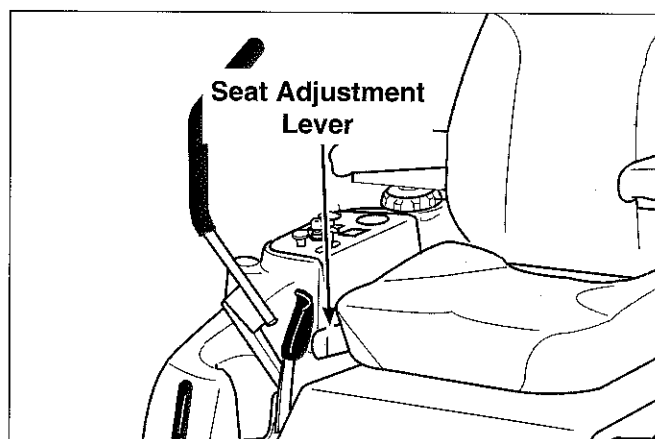

Figure 28. Seat Adjustment

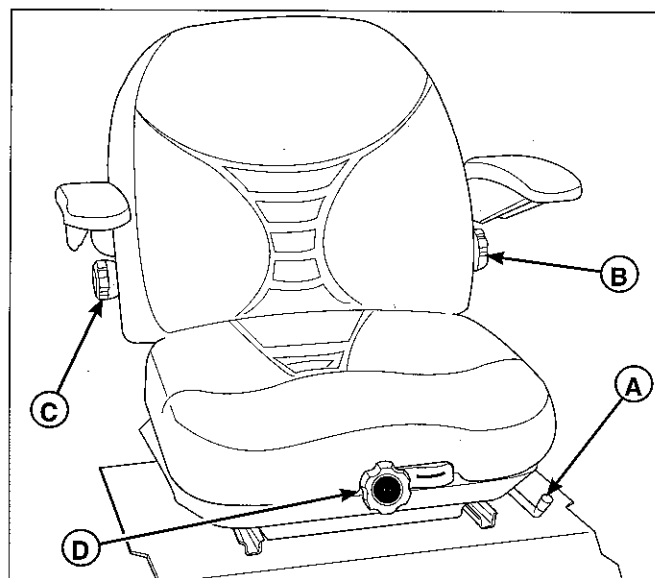

Figure 29. Suspension Seat Adjustment  
A. Forward / Backward Seat Adjustment Lever  
B. Lumbar Adjustment Knob  
C. Back Angle Adjustment Knob  
D. Suspension Adjustment Knob

## Ground Speed Control Lever Adjustment

The control levers can be adjusted in three ways. The alignment of the control levers, the placement of the levers (how close the ends are to one another) and the height of the levers can be adjusted.

### To Adjust the Handle Alignment

Loosen the mount bolts (A, Figure 30) and pivot the lever(s) (C) to align with each other.

### To Adjust the Handle Placement

Loosen the jam nuts and adjust the placement bolt (B) in or out to properly adjust the lever end spacing.

### To Adjust the Handle Height

Remove the mounting hardware and reposition the handle either up or down from its original position. You will need to readjust the handle alignment as described above.

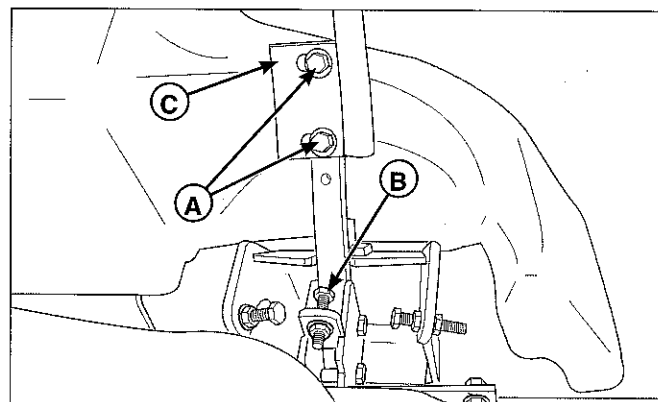

Figure 30. Control Lever Adjustment  
A. Alignment Hardware  
B. Placement Hardware  
C. Ground Speed Control Lever

## Speed Balancing Adjustment

If the rider veers to the right or left when the ground speed control levers are in the maximum forward position, the top speed of each of these levers can be balanced by turning the adjustment bolt(s) (A, Figure 31). Only adjust the speed of the wheel that is traveling faster.

### To Reduce the Speed of the Faster Wheel

1. Loosen the flange nuts.
2. Turn the top speed adjustment bolt COUNTER-CLOCKWISE to reduce the speed.
3. Retighten the flange nuts when adjustment is complete.

## WARNING

**DO NOT** adjust the tractor for a faster overall speed forward or reverse than it was designed for.

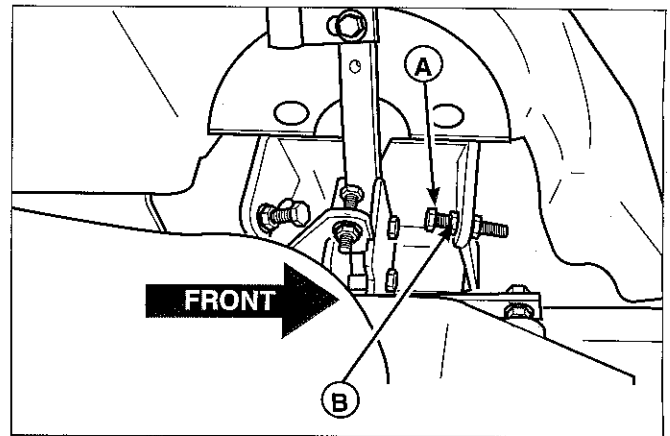

Figure 31. Top Speed Adjustment  
A. Top Speed Adjustment Bolt  
B. Flange Nut

## Neutral Adjustment

If the tractor “creeps” while the ground speed control levers are locked in NEUTRAL, then it may be necessary to adjust the linkage rod.

*NOTE: Perform this adjustment on a hard, level surface such as a concrete floor.*

1. Disengage the PTO, engage the parking brake and turn off the engine.
2. There are three (3) nuts on the linkage rod. The first two are to be used together to turn the rod and the third (towards the front of the machine) is used to lock the rod in place. Loosen the jam nut that locks against the clevis (B, Figure 32) and turn the linkage rod (A) to adjust. If the machine creeps forward, turn the rod CLOCKWISE (while standing at the rear of the machine, facing forward), if the machine creeps backward, turn the rod COUNTER-CLOCKWISE.
3. Lock the jam nut (B) against the clevis when neutral is achieved.

*NOTE: This adjustment should not be performed while the machine is running. It may take several attempts to achieve neutral, depending upon how much the machine creeps.*

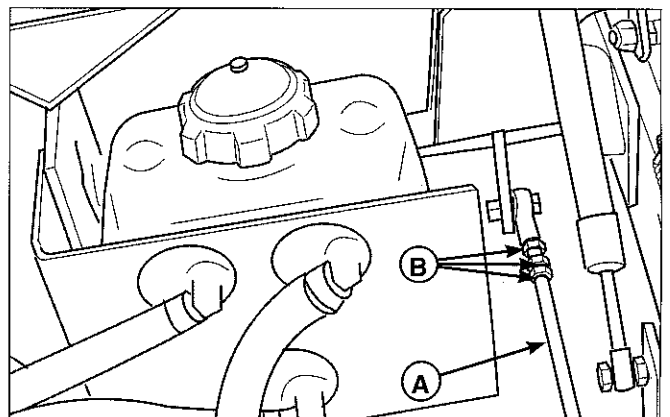

Figure 32. Neutral Adjustment  
A. Adjustment Linkage Rod  
B. Nuts

## Return-to-Neutral Adjustment

To determine if it is necessary to adjust the neutral return, perform the following steps.

1. Disengage the PTO, engage the parking brake and turn off the engine.
2. Move the ground speed control levers into the operating position, pull levers rearward and release.
3. Move the ground speed control levers towards the neutral position. If the levers do not align with the notches in the neutral lock plate, it is necessary to adjust the neutral return rod (C, Figure 33).

### Adjustment

1. Loosen the jam nut (B) locked against the ball joint (A).
2. Turn the neutral return rod (C) to adjust handle position (see Figure 33).
3. Pull lever rearward and release to check position again. Adjust as necessary to align levers with notches.
4. Once the lever alignment has been adjusted, lock jam nut against the ball joint.

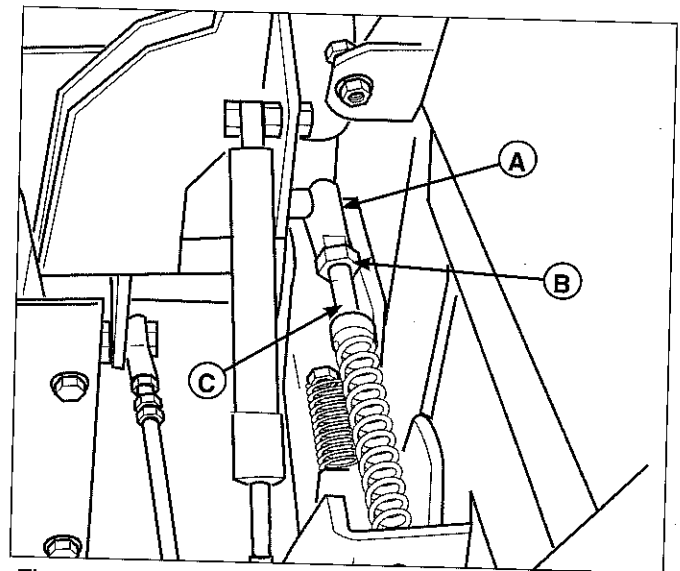

Figure 33. Neutral Return Adjustment

- A. Ball Joint
- B. Jam Nut
- C. Neutral Return Rod

## Parking Brake Adjustment

1. Disengage the PTO, stop the engine, block the front wheels, remove the ignition key, and engage the parking brake.
2. Locate the upper brake spring (A, Figure 34).
3. With the parking brake engaged, measure the compressed spring length. The spring should be 2" to 2-1/8" (5,0 - 5,4 cm) when compressed.
4. If the spring is not within this range, jack up the rear of the machine and secure with jackstands. Remove both drive tires.
5. Locate the lower brake spring and adjustment clevis (A & B, Figure 35).
6. Release the parking brake and disconnect the clevis (B) from the caliper lever (C). Turn the clevis to compress or release the upper spring. Lock the nut against the clevis and reinstall the clevis onto the caliper lever.

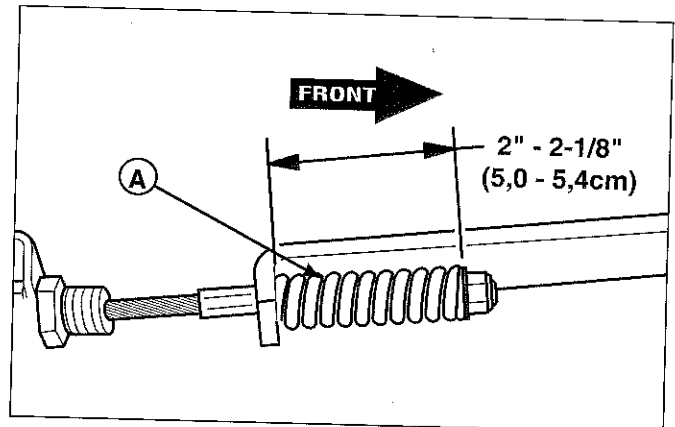

Figure 34. Parking Brake Adjustment

- A. Upper Brake Spring

## **CAUTION**

Do not adjust the spring to be shorter than 2" (5,0 cm) when compressed. This may damage the brake caliper.

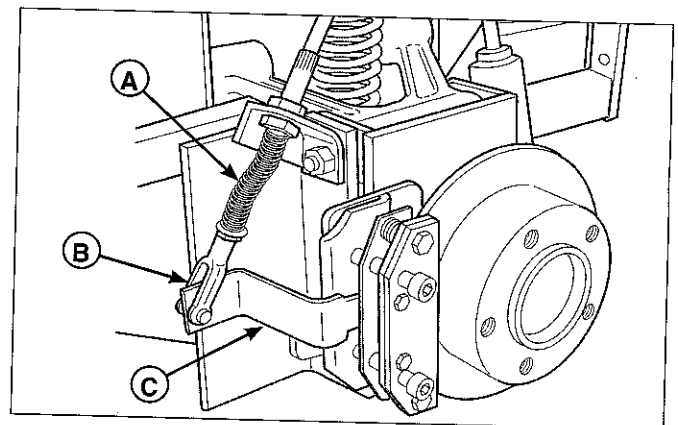

Figure 35. Parking Brake Adjustment

- A. Lower Brake Spring
- B. Adjustment Clevis
- C. Caliper Lever

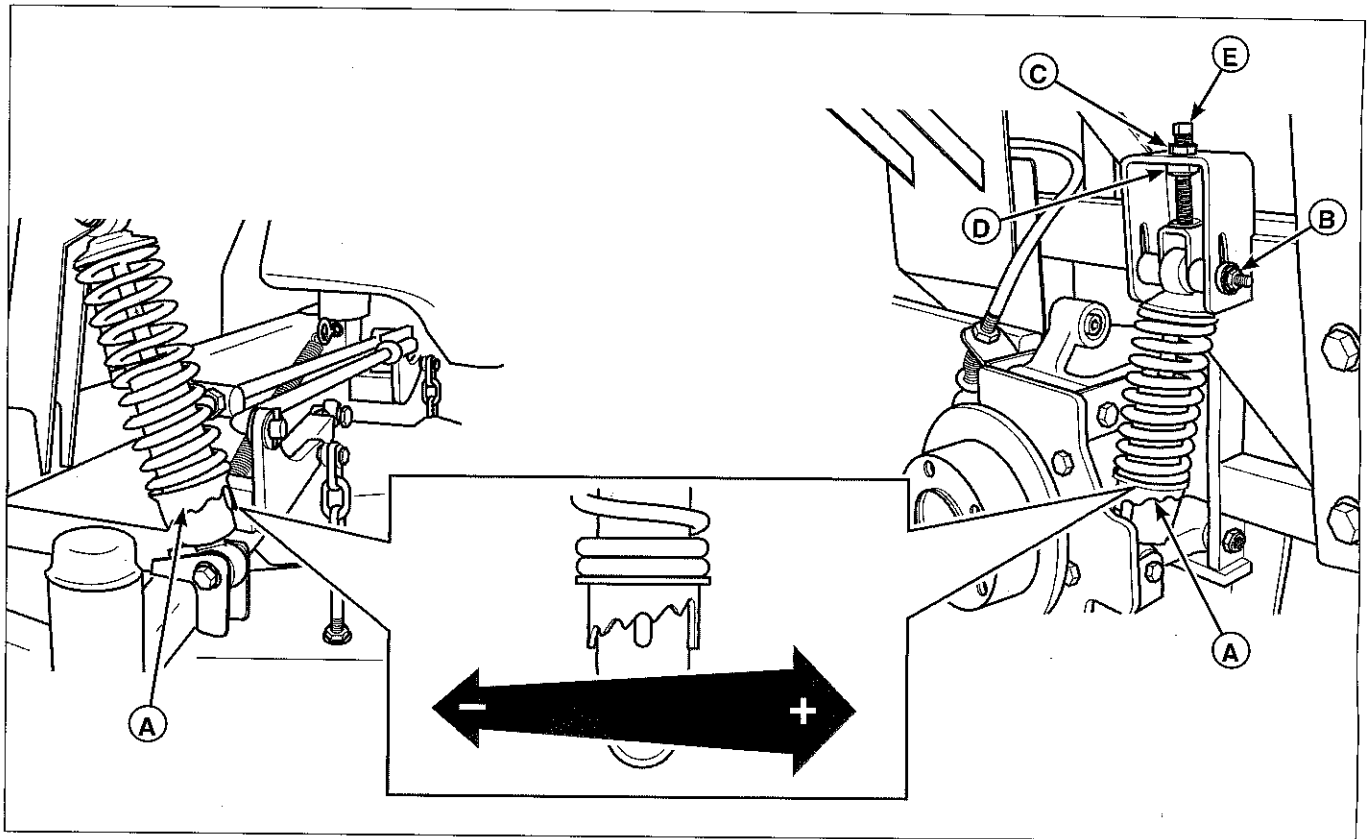

Figure 36. Suspension Adjustment

- A. Pre-load Adjuster
- B. Shock Mounting Bolt
- C. Top Jam Nut
- D. Bottom Jam Nut
- E. Adjuster Bolt

## Suspension Adjustment

The shock assembly can be adjusted to vary the amount of pre-load applied to the springs. This allows the operator to maintain the ride height.

Use less pre-load for light weight operators. Use more pre-load for heavy weight operators. Adjust the rear suspension height if additional weight (ie. grass collector) is being added to the frame.

### To adjust the spring pre-load:

1. Park machine on a flat, level surface. Disengage the PTO, stop the engine and engage the parking brake.
2. See Figure 36. Using the supplied spanner wrench (p/n 5022853), insert the tip of the wrench into the notch in the pre-load adjuster. While holding the wrench with both hands, turn **CLOCKWISE** to decrease the pre-load, turn **COUNTER-CLOCKWISE** to increase the pre-load. Make sure that for each pair of shocks that the left-hand and right-hand are set to the same amount of pre-load.

## **⚠** WARNING

Use two hands when adjusting the shock springs. This will prevent the wrench from slipping while pressure is being applied.

*NOTE: Spanner wrench is located under the seat. Rear tires must be removed to adjust the rear suspension.*

*NOTE: It is recommended that the rear suspension be adjusted stiffer due to the added weight of the collection system.*

### To adjust the rear suspension height:

1. Loosen the shock mounting bolt (B).
2. Loosen the top jam nut (C).
3. While holding the bottom jam nut (D) with a wrench, turn the adjuster bolt (E) **CLOCKWISE** to raise the rear suspension or **COUNTER-CLOCKWISE** to lower the rear suspension.
4. Tighten the top jam nut (C).
5. Tighten the shock mounting bolt (B).
6. Repeat for other side.

*NOTE: Both sides must be adjusted evenly to prevent the rider frame from tilting to one side.*

## Cutting Height Adjustment

### **WARNING**

Before checking mower, shut off PTO and engine. Allow all moving parts to stop. Remove ignition key, then disconnect the spark plug wire and fasten it away from the spark plug.

The cutting height adjustment pin (A, Figure 37) controls the mower cutting height. The cutting height is adjustable between 1-1/2" (3,8cm) and 5" (12,7cm) in 1/4" (0,64cm) increments.

1. Depress the deck lift foot pedal (B, Figure 37) until it locks into the 5" (12,7 cm) position.
2. Place the cutting height adjustment pin in the desired cutting height.
3. Depress the deck lift foot pedal then push the lock lever (C) towards the right to release the lock.
4. Release the deck lift foot pedal until it comes to rest against the cutting height adjustment pin.

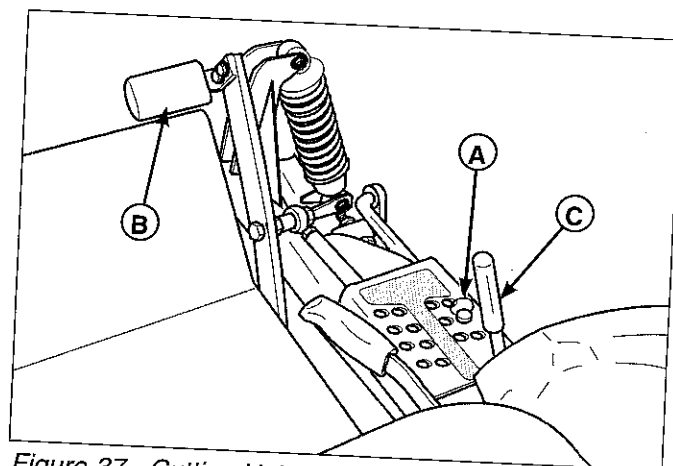

Figure 37. Cutting Height Adjustment  
A. Cutting Height Adjustment Pin  
B. Deck Lift Foot Pedal  
C. Deck Lift Lock Lever

## Foot Pedal Adjustment

The deck lift foot pedal can be adjusted to accommodate the operator's height for optimal comfort.

### To adjust pedal position:

1. Remove the foot pedal (A, Figure 38) from the pedal mount tab (B).
2. Remove the pedal mount hardware (C) and rotate the tab 180 degrees.
3. Reinstall the pedal mount hardware and tighten securely.
4. Reinstall the foot pedal on the pedal mount tab in the proper orientation as shown in Figure 38.

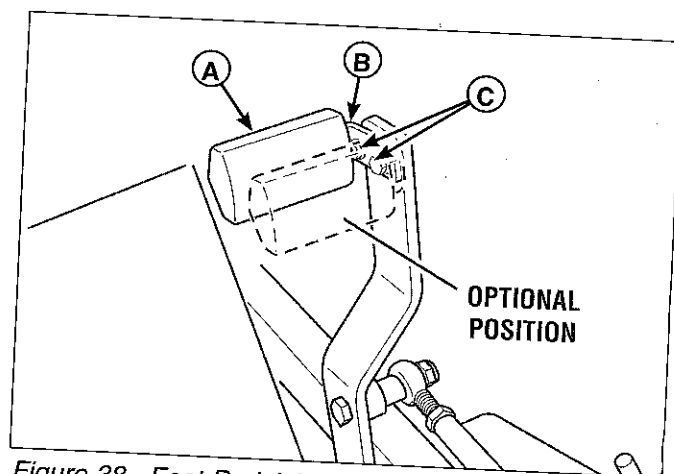

Figure 38. Foot Pedal Adjustment  
A. Deck Lift Foot Pedal  
B. Pedal Mount Tab  
C. Pedal Mount Hardware

## Deck Lift Rod Timing Adjustment

1. Park machine on a flat, level surface. Disengage the PTO, stop the engine and engage the parking brake. Rear tires must be inflated to 15 psi (1,03 bar); front tires to 25 psi (1,72 bar).
2. To check the inner lift rod timing, measure and record the distance between the inner lift pivots and the inner rod pivots. Repeat for other side of unit. See Figure 39.
3. To check the outer lift rod timing, measure and record the distance between the outer lift pivots and the outer rod pivots. Repeat for other side of unit. See Figure 39.
4. If the measurements for the inner rods are equal, and the measurements for the outer rods are equal, no further adjustment is required. If the measurements are NOT equal (greater than 1/8" (3,17mm) difference), adjustment is required, continue with Step 5.
5. Lock the deck lift pedal in the 5" (12,7cm) position. Remove the cutting height adjustment pin and lower the mower deck.
6. To ensure that the deck is in the lowest position, push the pedal by hand towards the rear of the unit and install the height adjustment pin in the 3" (7.6cm) position to hold in place. See Figure 40.
7. Block up the mower deck until all hanger chains are slack.
8. Refer to Figure 41. To adjust the inner lift rod, adjust the 5/8" hex nuts on either side of the front lift pivot until the measurements are equal. Repeat for other side.
9. Refer to Figure 41. To adjust the outer lift rod, remove the coil pins securing the outer lift rod to the lift levers. Remove the outer lift rod from the unit and add or remove 5/8" SAE washers from in between the deck lift rod and the lift link until measurements are equal. Reinstall the coil pins and washer (on front lift lever). Repeat for other side.
10. Remove blocks from under the mower deck.
11. While pushing the pedal by hand towards the rear of the unit, remove the the cutting height adjustment pin from in front of the deck lift pedal arm. Lift mower deck and reinstall adjustment pin in desired mowing height.

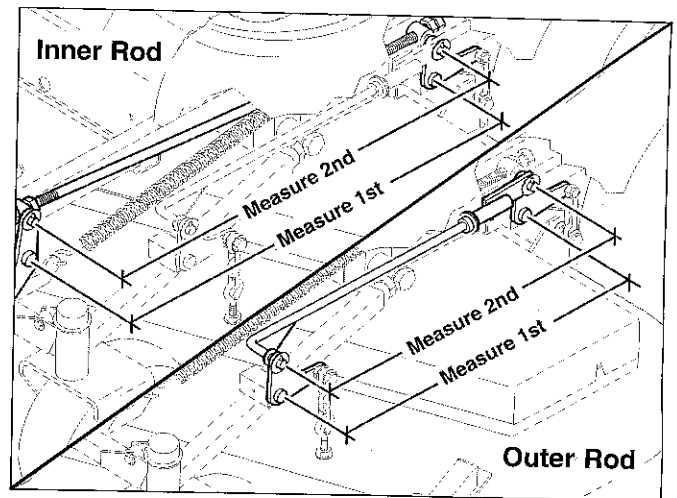

Figure 39. Measure the Inner & Outer Lift Rods

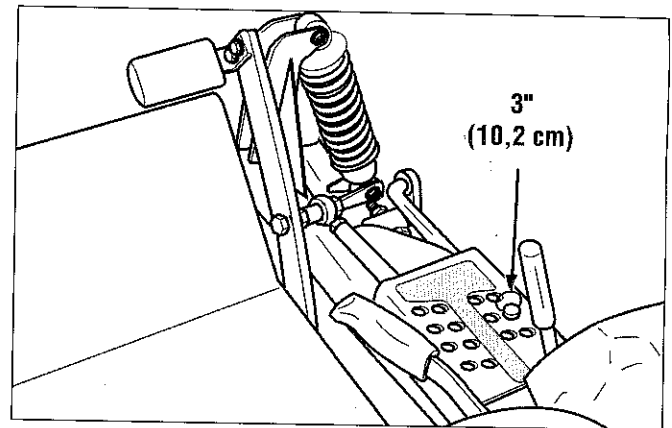

Figure 40. Deck Lift Pedal & Pin Position

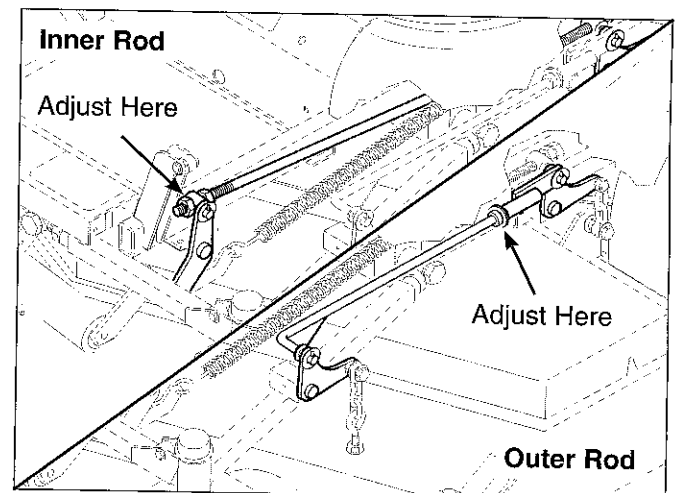

Figure 41. Adjust the Inner & Outer Lift Rods

# Troubleshooting, Adjustment & Service

## Deck Leveling Adjustment

**NOTE:** Before adjusting the deck level, the deck lift rod timing must be checked and/or adjusted.

1. Park machine on a flat, level surface. Disengage the PTO, stop the engine and engage the parking brake. Rear tires must be inflated to 15 psi (1,03 bar); front tires to 25 psi (1,72 bar).
2. Lock the deck lift pedal in the 5" (12,7cm) position. Place the deck height adjustment pin in the 4" position and lower deck the lift pedal until the arm contacts the pin.
3. Place 2 x 4 blocks under each corner of the mower deck with the 3-1/2" sides being vertical. See Figure 42.
4. Adjust the front eyebolts until the chains are tight and the deck is still resting on the 2 x 4's. Tighten jam nuts. See Figure 43.
5. Loosen the nuts and allow the rear of the deck to rest on the 2 x 4's. Slide the chains down in the slots until the chains are tight and tighten the nuts. See Figure 43.
6. Remove all 2 x 4 blocks from under the mower deck.

### CAUTION

**Avoid injury! Mower blades are sharp.**

**Always wear gloves when handling blades or working near blades.**

7. See Figure 44. Position the outside mower blades so they face front-to-back.
8. Measure from the front tip of the blade from the cutting edge to the ground. Measure from the rear tip of the blade from the cutting edge to the ground. The measurement should be 4" (10,2 cm). Repeat this process for the other side of the machine.

## Deck Lift Spring

The deck lift springs (A, Figure 45) are factory set to provide optimal lifting performance.

Although it is fastened with a multi-position anchor, this is **NOT AN ADJUSTMENT POINT**.

**DO NOT** attempt to adjust the spring length or lifting performance will be compromised.

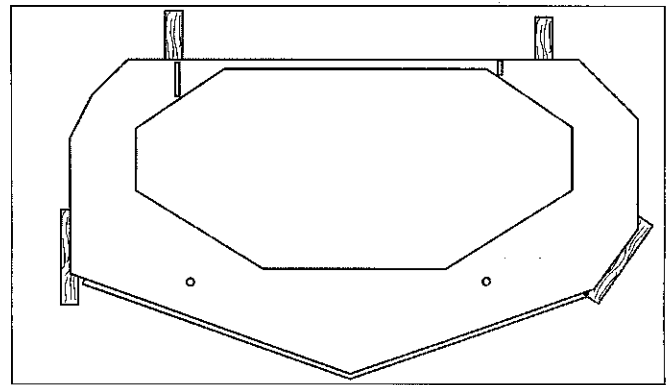

Figure 42. 2 x 4 Locations

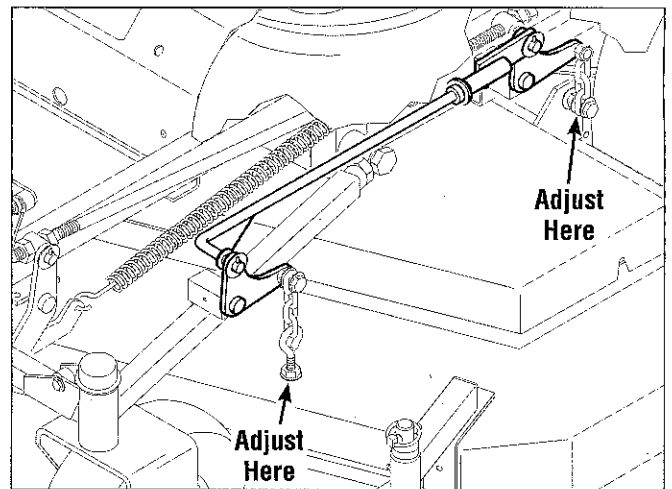

Figure 43. Deck Level & Spring Length Adjustment

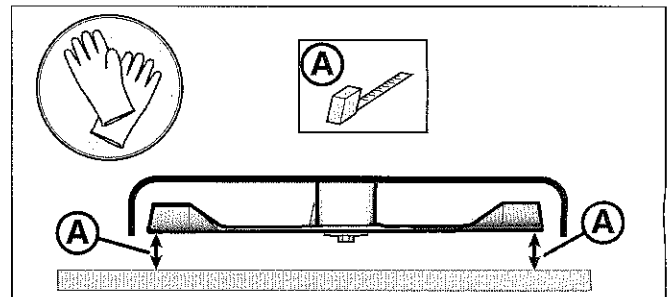

Figure 44. Checking the Blade Height Adjustment

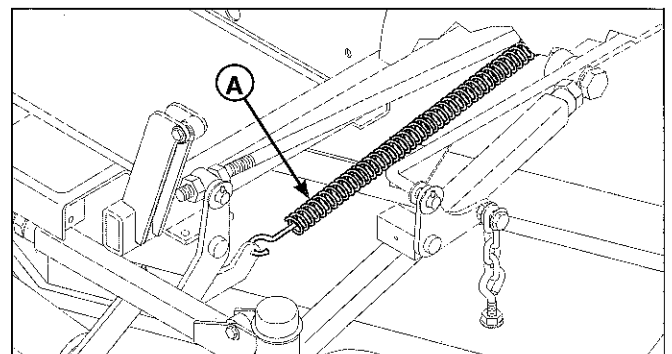

Figure 45. Deck Lift Spring Location  
A. Deck Lift Spring

## PTO Clutch Adjustment

### **⚠ WARNING**

To avoid serious injury, perform adjustments only with engine stopped, key removed and tractor on level ground.

All other Models: S/N: All

Briggs & Stratton 543777-0120-E1 Models: S/N: 2013556397 & Above:

Check the PTO clutch adjustment after the initial 25 hour break-in period and then after every 100 hours of operation. Also perform the following procedure if the clutch is slipping or will not engage, or if a new clutch has been installed.

1. Remove key from ignition switch and disconnect spark plug wires to prevent the possibility of accidental starting while the PTO is being adjusted.
2. See Figure 46. Note the position of the 3 adjustment windows (A) in the side of the brake plate and the nylock adjustment nuts (B).
3. Insert a .016"-.018" (0,40-0,45mm) feeler gauge (C) through each window, positioning the gauge between the rotor face and the armature face as shown in Figure 47.
4. Alternately tighten the adjustment nuts (B, Figure 47) until the rotor face and armature face just contacts the gauge.
5. Check the windows for an equal amount of drag when the gauge is inserted and removed, and make any necessary adjustments by tightening or loosening the adjustment nuts.

**NOTE:** The actual air gap between the rotor and armature may vary even after performing the adjustment procedure. This is due to dimensional variations on component parts, and is an acceptable condition.

6. Check the mower blade stopping time. See **BLADE BRAKE CHECK**. The mower blades and mower drive belt should come to a complete stop within seven (7) seconds after the electric PTO switch is turned off.

Briggs & Stratton 543777-0120-E1 Models: S/N: 2013556397 & Above:

If the clutch is slipping or the clutch will not engage, the air gap can be adjusted by removing the re-gap shim to allow the clutch to continue to function.

1. Loosen both brake mounting bolts (A, Figure 48) 1/2 to 1 full turn as shown in Figure 48.

**IMPORTANT NOTE:** Do not remove the brake pole (B, Figure 48) from the clutch. The brake pole must remain in the correct position to ensure proper brake torque.

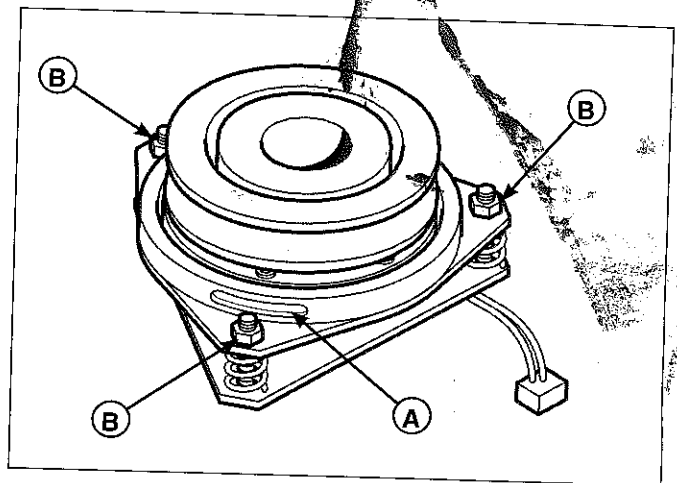

Figure 46. PTO Clutch Adjustment  
A. Adjustment Window (Qty. 3, one shown)  
B. Adjustment Nut

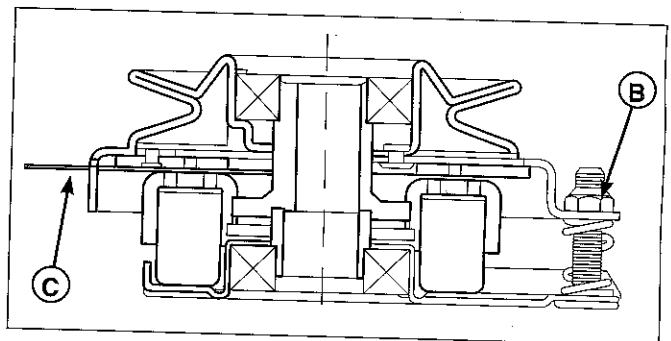

Figure 47. Adjust PTO Clutch  
A. Window  
B. Adjustment Nut  
C. .016"-.018" (0,40-0,45mm) Feeler Gauge

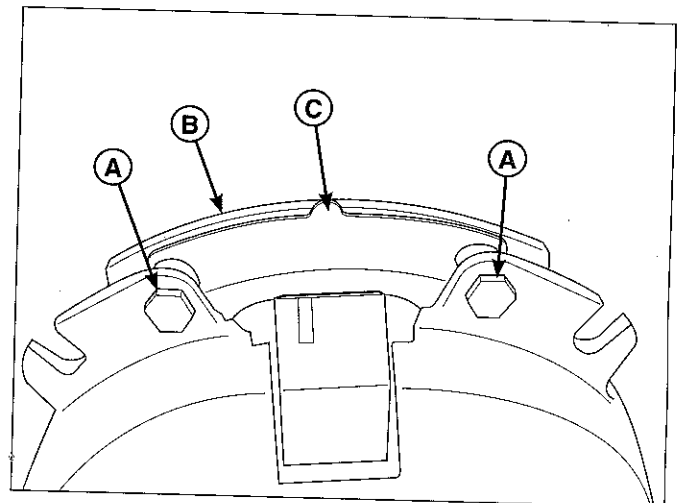

Figure 48. PTO Clutch Adjustment  
A. Brake Mounting Bolts  
B. Brake Pole  
C. Re-gap Shim

## Deck Leveling Adjustment

*NOTE: Before adjusting the deck level, the deck lift rod timing must be checked and/or adjusted.*

1. Park machine on a flat, level surface. Disengage the PTO, stop the engine and engage the parking brake. Rear tires must be inflated to 15 psi (1,03 bar); front tires to 25 psi (1,72 bar).
2. Lock the deck lift pedal in the 5" (12,7cm) position. Place the deck height adjustment pin in the 4" position and lower deck the lift pedal until the arm contacts the pin.
3. Place 2 x 4 blocks under each corner of the mower deck with the 3-1/2" sides being vertical. See Figure 42.
4. Adjust the front eyebolts until the chains are tight and the deck is still resting on the 2 x 4's. Tighten jam nuts. See Figure 43.
5. Loosen the nuts and allow the rear of the deck to rest on the 2 x 4's. Slide the chains down in the slots until the chains are tight and tighten the nuts. See Figure 43.
6. Remove all 2 x 4 blocks from under the mower deck.

### **CAUTION**

**Avoid injury! Mower blades are sharp. Always wear gloves when handling blades or working near blades.**

7. See Figure 44. Position the outside mower blades so they face front-to-back.
8. Measure from the front tip of the blade from the cutting edge to the ground. Measure from the rear tip of the blade from the cutting edge to the ground. The measurement should be 4" (10,2 cm). Repeat this process for the other side of the machine.

## Deck Lift Spring

The deck lift springs (A, Figure 45) are factory set to provide optimal lifting performance.

Although it is fastened with a multi-position anchor, this is **NOT AN ADJUSTMENT POINT**.

**DO NOT** attempt to adjust the spring length or lifting performance will be compromised.

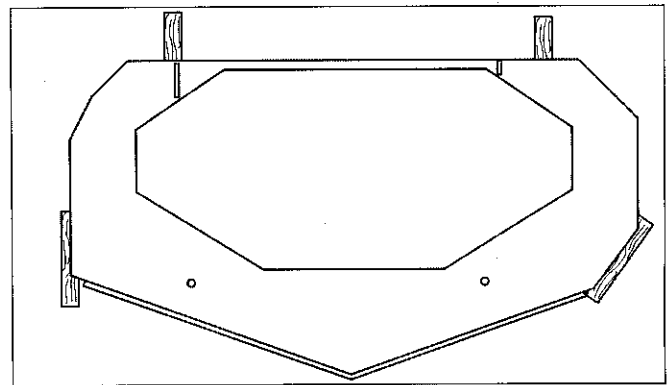

Figure 42. 2 x 4 Locations

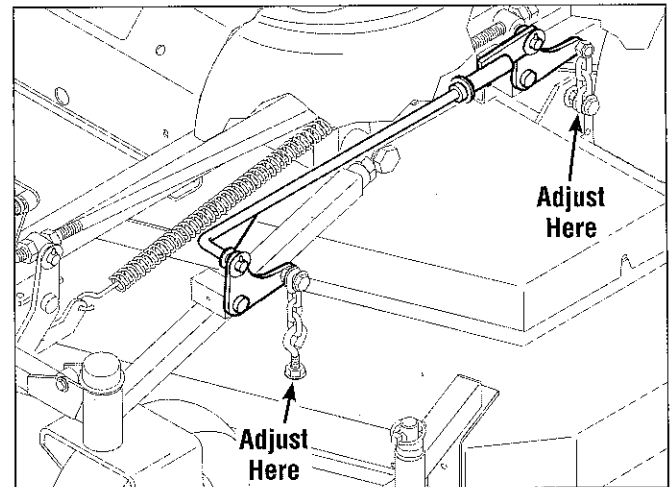

Figure 43. Deck Level & Spring Length Adjustment

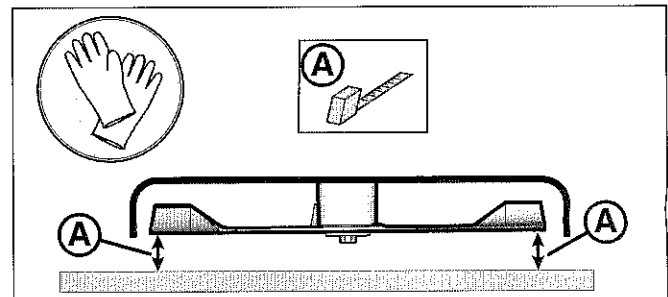

Figure 44. Checking the Blade Height Adjustment

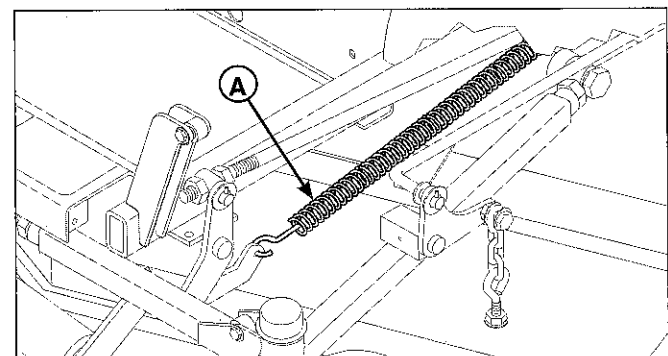

Figure 45. Deck Lift Spring Location  
A. Deck Lift Spring

## PTO Clutch Adjustment

### **WARNING**

To avoid serious injury, perform adjustments only with engine stopped, key removed and tractor on level ground.

**All other Models: S/N: All  
Briggs & Stratton 543777-0120-E1 Models: S/N:  
2013556397 & Above:**

Check the PTO clutch adjustment after the initial 25 hour break-in period and then after every 100 hours of operation. Also perform the following procedure if the clutch is slipping or will not engage, or if a new clutch has been installed.

1. Remove key from ignition switch and disconnect spark plug wires to prevent the possibility of accidental starting while the PTO is being adjusted.
2. See Figure 46. Note the position of the 3 adjustment windows (A) in the side of the brake plate and the nylock adjustment nuts (B).
3. Insert a .016"-.018" (0,40-0,45mm) feeler gauge (C) through each window, positioning the gauge between the rotor face and the armature face as shown in Figure 47.
4. Alternately tighten the adjustment nuts (B, Figure 47) until the rotor face and armature face just contacts the gauge.
5. Check the windows for an equal amount of drag when the gauge is inserted and removed, and make any necessary adjustments by tightening or loosening the adjustment nuts.

**NOTE:** The actual air gap between the rotor and armature may vary even after performing the adjustment procedure. This is due to dimensional variations on component parts, and is an acceptable condition.

6. Check the mower blade stopping time. See **BLADE BRAKE CHECK**. The mower blades and mower drive belt should come to a complete stop within seven (7) seconds after the electric PTO switch is turned off.

**Briggs & Stratton 543777-0120-E1 Models: S/N:  
2013556397 & Above:**

If the clutch is slipping or the clutch will not engage, the air gap can be adjusted by removing the re-gap shim to allow the clutch to continue to function.

1. Loosen both brake mounting bolts (A, Figure 48) 1/2 to 1 full turn as shown in Figure 48.

**IMPORTANT NOTE:** Do not remove the brake pole (B, Figure 48) from the clutch. The brake pole must remain in the correct position to ensure proper brake torque.

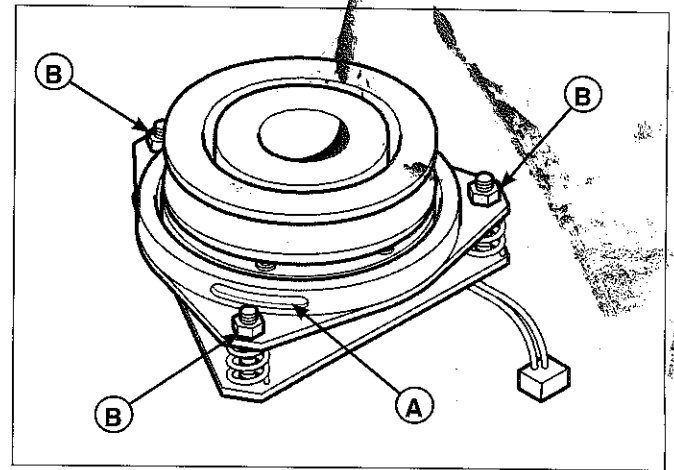

Figure 46. PTO Clutch Adjustment  
A. Adjustment Window (Qty. 3, one shown)  
B. Adjustment Nut

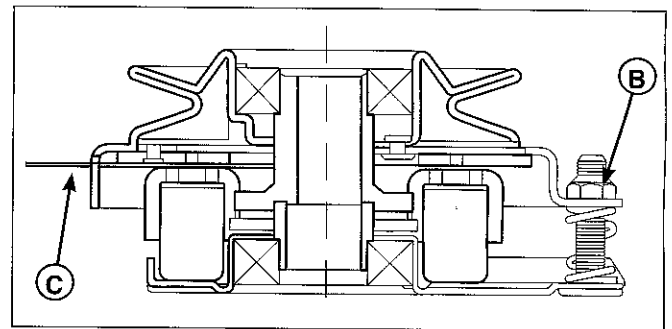

Figure 47. Adjust PTO Clutch  
A. Window  
B. Adjustment Nut  
C. .016"-.018" (0,40-0,45mm) Feeler Gauge

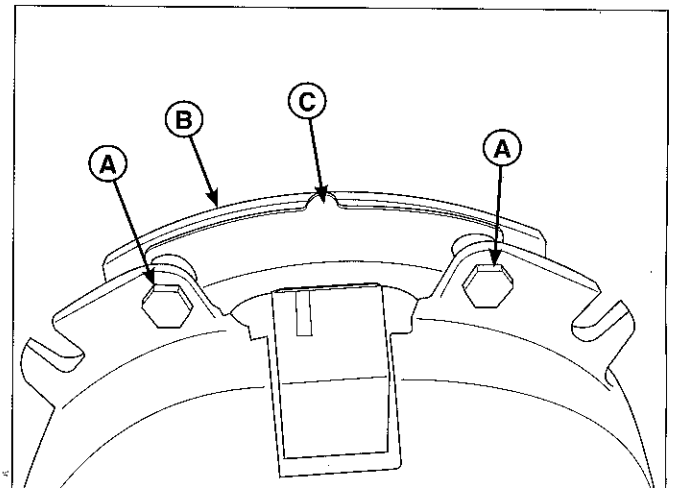

Figure 48. PTO Clutch Adjustment  
A. Brake Mounting Bolts  
B. Brake Pole  
C. Re-gap Shim

## Troubleshooting, Adjustment & Service

- Using needle nose pliers, take hold of the tab and remove the re-gap shim (C).
- Re-torque each brake mounting bolt to 10 ft. lbs. (13,5 Nm)
- Using a .010" thick feeler gauge (A, Figure 49), verify that the gap is present between the rotor and armature face on both sides of the brake pole as shown.
  - If the gap is less than .010, the clutch will need to be replaced;
  - If sufficient gap is present, procedure to BLADE BRAKE CHECK procedure.

### Blade Brake Check

Mower blades and mower drive belt should come to a complete stop within seven (7) seconds after electric PTO switch is turned off.

- With parking brake engaged, PTO disengaged and an operator in the seat, start the engine engine.
- Have an assistant observe the mower drive belt through the open end of the left-hand arbor cover. Engage the PTO and wait several seconds. Disengage the PTO and check the amount of time it takes for the mower drive belt to stop.
- If the mower drive belt does not stop within seven (7) seconds, perform the PTO Clutch Adjustment. If the belt still does not stop within seven (7) seconds, see your dealer.

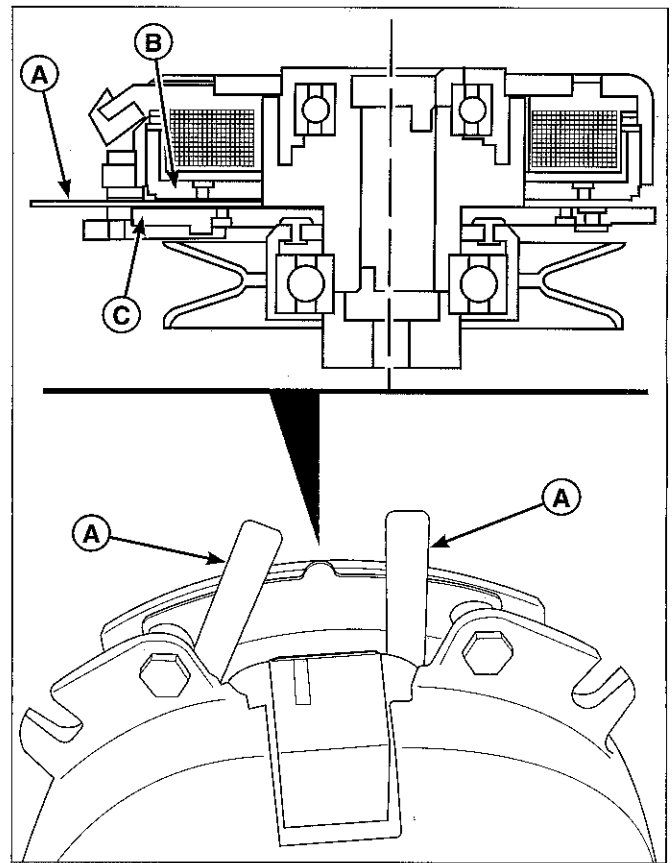

Figure 49. Adjust PTO Clutch

- A. .010" Thick Feeler Gauge  
B. Rotor  
C. Armature Face

## Hydraulic Pump Drive Belt Replacment

1. Park the tractor on a smooth, level surface such as a concrete floor. Disengage the PTO, engage the parking brake, turn off the engine, and remove the ignition key.
2. Remove the PTO drive belt (see MOWER BELT REPLACEMENT for removal instructions).
3. Loosen the nut towards the front of the machine on the spring anchor hook (H, Figure 50) to release the majority of the belt tension. Use caution and remove the nut to completely release the tension.
4. Remove the old belt and replace it with the new one. Make sure the V-side of the belt runs in the grooves of the crankshaft pulley and pump pulleys (B & C).
5. Reinstall the anchor hook (H) into the anchor tab and loosely fasten the nut. Adjust the spring until a measurement of 7-3/4" (19,7cm) is achieved from the outside of the spring hooks. Tighten nut.
6. Reinstall the PTO drive belt.

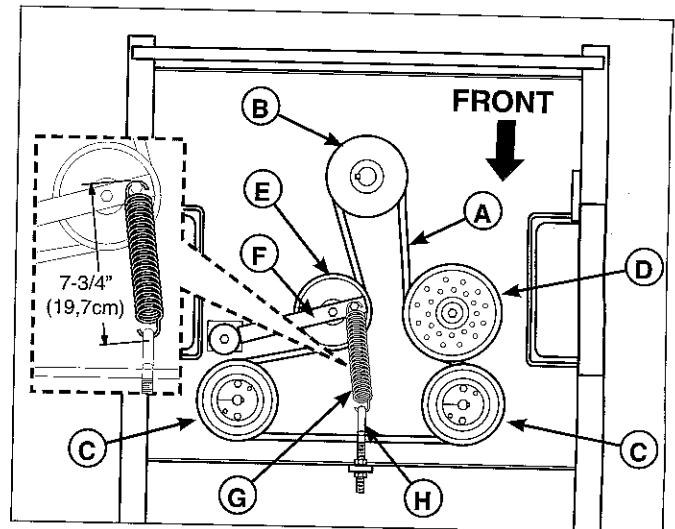

Figure 50. Hydraulic Pump Drive Belt Replacement

- A. Pump Drive Belt
- B. Crankshaft Pulley
- C. Pump Pulley
- D. Idler Pulley (stationary)
- E. Idler Pulley
- F. Idler Arm
- G. Spring
- H. Spring Anchor Hook

# Troubleshooting, Adjustment & Service

## Mower Belt Replacment



To avoid damaging belts, **DO NOT PRY BELTS OVER PULLEYS.**

1. Park the tractor on a smooth, level surface such as a concrete floor. Disengage the PTO, engage the parking brake, turn off the engine, and remove the ignition key.

### **WARNING**

Use extreme caution when rotating the idler arm with the breaker bar or combination wrench, due to the increased tension in the spring as the idler arm is being rotated. Injury may result if the breaker bar is prematurely released while the spring is under tension.

2. **For 61" deck:** Using a 1/2" breaker bar, place the square end in the square hole located in the end of the idler arm (A, Figure 51). Carefully rotate the breaker bar **COUNTER-CLOCKWISE**, which will relieve the tension on the belt exerted from the idler arm.
2. **For 72" deck:** Using a 3/4" combination wrench, place the box end on the nut (A, Figure 52) securing the idler pulley located in the end of the idler arm. Carefully rotate the wrench **CLOCKWISE**, which will relieve the tension on the belt exerted from the idler arm.
3. Slide the drive belt over the edge of the stationary idler pulley (B). Carefully release the tension on the breaker bar or combination wrench until the idler arm comes to a stop.
4. Remove the old belt and replace with a new one. Make sure the V-side of the belt runs in the pulley grooves (Figure 53).
5. **For 61" deck:** Install the drive belt on the PTO pulley, the spindle pulleys and all idler pulleys except the stationary pulley (B, Figure 51). Carefully rotate the breaker bar **COUNTER-CLOCKWISE** and install the belt on the stationary idler pulley (B). Carefully release the tension on the breaker bar.
5. **For 72" deck:** Install the drive belt on the PTO pulley, the spindle pulleys and all idler pulleys except the stationary pulley (B, Figure 52). Carefully rotate the combination wrench **CLOCKWISE** and install the belt on the stationary idler pulley (B). Carefully release the tension on the combination wrench.
6. Run the mower under no-load condition for about 5 minutes to break-in the new belt.

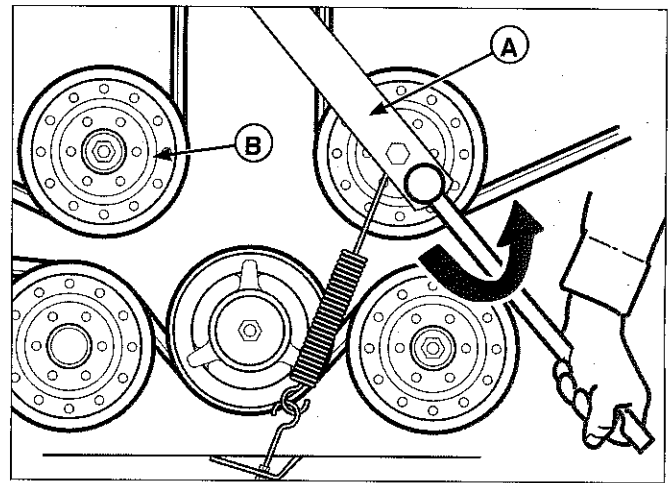

Figure 51. Mower PTO Belt (61" Mower Deck)  
A. Idler Arm  
B. Stationary Idler Pulley

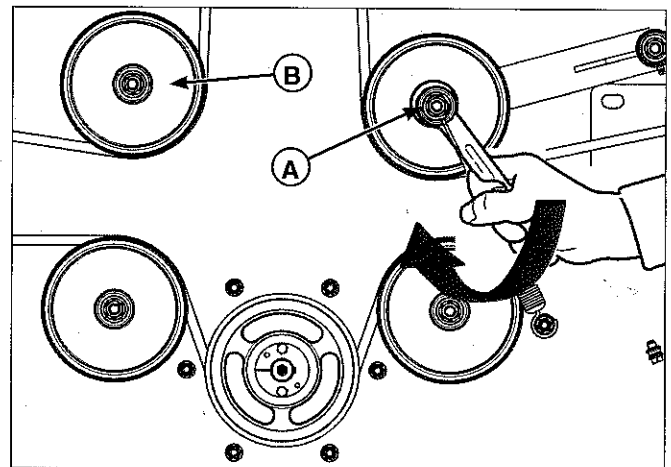

Figure 52. Mower PTO Belt (72" Mower Deck)  
A. Nut  
B. Stationary Idler Pulley

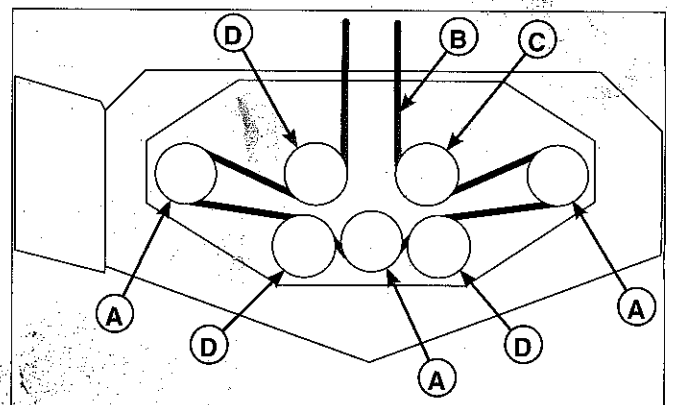

Figure 53. Mower PTO Belt Routing  
A. Spindle Pulley  
B. PTO Drive Belt  
C. Spring-loaded Idler Pulley  
D. Stationary Idler Pulley

## Check the Mower Belt Idler Tensioner Spring Length

1. Park the machine on a smooth level surface such as a concrete floor. Disengage the PTO, engage the parking brake, turn off the engine and remove the ignition key.
2. Lower the mower deck to its lowest cutting position.
3. Use the Mower Belt Idler Spring Length chart to determine the correct spring length (E, Figure 54).
4. Measure the coil length of the mower belt tensioner spring (A.). The measurement should equal the measurement as designated in the chart. If the measurement does not equal the measurement as designated in the chart, adjust the anchor eyebolt (B).

## Adjusting the Mower Belt Idler Spring Length

1. Loosen the jam nut (C).
2. Turn the adjustment nut (D) until a measurement as designated in the chart is achieved.
3. Retighten the jam nut.

| Mower Belt Idler Spring Length | Measurement    |      |
|--------------------------------|----------------|------|
|                                | inch           | cm   |
|                                | 61" Mower Deck | 7    |
| 72" Mower Deck                 | 6-1/4          | 15.9 |

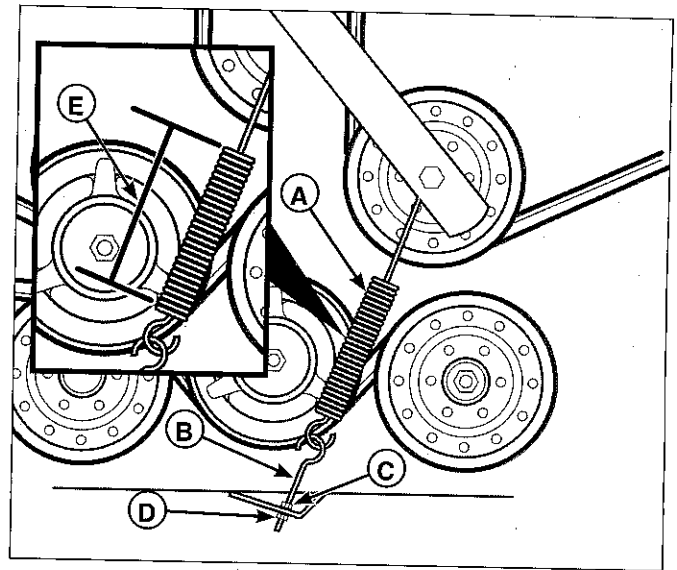

Figure 54. Mower Belt Idler Spring Length  
 A. Mower Belt Tensioner Spring  
 B. Anchor Eyebolt  
 C. Jam Nut  
 D. Adjustment Nut  
 E. Measurement

## Battery Service

### **WARNING**

Keep open flames and sparks away from the battery; the gasses coming from it are highly explosive. Ventilate the battery well during charging.

### Checking Battery Voltage

A voltmeter can be used to determine condition of battery. When engine is off, the voltmeter shows battery voltage, which should be 12 volts. When engine is running, the voltmeter shows voltage of charging circuit which normally is 13 to 14 volts.

A dead battery or one too weak to start the engine may not mean the battery needs to be replaced. For example, it may mean that the alternator is not charging the battery properly. If there is any doubt about the cause of the problem, see your dealer. If you need to replace the battery, follow the steps under Cleaning the Battery & Cables in the Regular Maintenance Section.

### Charging a Completely Discharged Battery

1. Be aware of all the safety precautions you should observe during the charging operation. If you are unfamiliar with the use of a battery charger and hydrometer, have the battery serviced by your dealer.
2. Add distilled water sufficient to cover the plate (fill to the proper level near the end of the charge). If the battery is extremely cold, allow it to warm before adding water because the water level will rise as it warms. Also, an extremely cold battery will not accept a normal charge until it becomes warm.
3. Always unplug or turn the charger off before attaching or removing the clamp connections.
4. Carefully attach the clamps to the battery in proper polarity (usually red to [+] positive and black to [-] negative).
5. While charging, periodically measure the temperature of the electrolyte. If the temperature exceeds 125° F (51.6° C), or if violent gassing or spewing of electrolyte occurs, the charging rate must be reduced or temporarily halted to prevent battery damage.

- Charge the battery until fully charged (until the specific gravity of the electrolyte is 1.250 or higher and the electrolyte temperature is at least 60° F). The best method of making certain a battery is fully charged, but not over charged, is to measure the specific gravity of a cell once per hour. The battery is fully charged when the cells are gassing freely at low charging rate and less than 0.003 change in specific gravity occurs over a three hour period.

## Jump Starting With Auxiliary (Booster) Battery

Jump starting is not recommended. However, if it must be done, follow these directions. Both booster and dis-charged batteries should be treated carefully when using jumper cables. Follow the steps below EXACTLY, being careful not to cause sparks. Refer to Figure 55.

- Both batteries must be of the same voltage.
- Position the vehicle with the booster battery adjacent to the vehicle with the discharged battery so that booster cables can be connected easily to the batteries in both vehicles. Make certain vehicles do not touch each other.
- Wear safety glasses and shield eyes and face from batteries at all times. Be sure vent caps are tight. Place damp cloth over vent caps on both batteries.
- Connect positive (+) cable to positive post of discharged battery (wired to starter or solenoid).
- Connect the other end of same cable to same post marked positive (+) on booster battery.
- Connect the second cable negative (-) to other post of booster battery.
- Make final connection on engine block of stalled vehicle away from battery. Do not lean over batteries.
- Start the engine of the vehicle with the booster battery. Wait a few minutes, then attempt to start the engine of the vehicle with the discharged battery.
- If the vehicle does not start after cranking for thirty seconds, STOP PROCEDURE. More than thirty seconds seldom starts the engine unless some mechanical adjustment is made.
- After starting, allow the engine to return to idle speed. Remove the cable connection at the engine or frame. Then remove the other end of the same cable from the booster battery.
- Remove the other cable by disconnecting at the discharged battery first and then disconnect the opposite end from the booster battery.
- Discard the damp cloths that were placed over the battery vent caps.

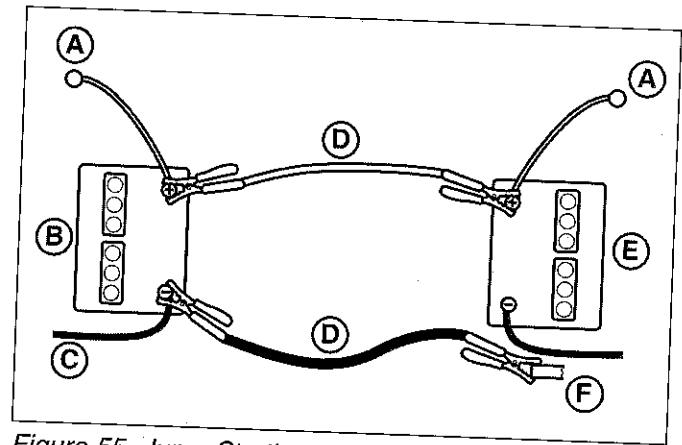

Figure 55. Jump Starting

**This hook-up is for negative grounded vehicles.**

| Callout | Description                |
|---------|----------------------------|
| A       | To Starter Switch          |
| B       | Starting Vehicle Battery   |
| C       | To Ground                  |
| D       | Jumper Cable               |
| E       | Discharged Vehicle Battery |
| F       | Engine Block               |

**Make sure vehicles do not touch.**

## ⚠ WARNING

Any procedure other than the preceding could result in:

- personal injury caused by electrolyte squirting out the battery vents,
- personal injury or property damage due to battery explosion,
- damage to the charging system of the booster vehicle or of the immobilized vehicle.

**Do not attempt to jump start a vehicle having a frozen battery because the battery may rupture or explode. If a frozen battery is suspected, examine all fill vents on the battery. If ice can be seen or if the electrolyte fluid cannot be seen, do not attempt to start with jumper cables as long as the battery remains frozen.**

## WARNING

For your personal safety, use extreme care when jump starting. Never expose battery to open flame or electric spark – battery action generates hydrogen gas which is flammable and explosive. Do not allow battery acid to contact skin, eyes, fabrics, or painted surfaces. Batteries contain a sulfuric acid solution which can cause serious personal injury or property damage.

When removing or installing battery cables, disconnect the negative cable **FIRST** and reconnect it **LAST**. If not done in this order, the positive terminal can be shorted to the frame by a tool.

To avoid engine damage, do not disconnect battery while engine is running. Be sure terminal connections are tight before starting.

## Specifications

Specifications are correct at time of printing and are subject to change without notice.

### ENGINE

Fits model 5900784

| 26 Gross HP† Kawasaki |   |
|-----------------------|---|
| Make                  | Kawasaki                                      |
| Model                 | FH731V  |
| Displacement          | 41.19 Cu. in (675 cc)                         |
| Electrical Schematic  | 12 Volt, 16 amp. Alternator, Battery: 340 CCA |
| Oil Capacity          | 2.4 US qt. (2.3 L) w/ Filter                  |

Fits models 5900788 & 5900503

| 30 Gross HP* Briggs & Stratton Vanguard |   |
|---|---|
| Make                                    | Briggs & Stratton                             |
| Model                                   | 542777-0113-E1                                |
| Displacement                            | 54.62 Cu. in (895 cc)                         |
| Electrical Schematic                    | 12 Volt, 20 amp. Alternator, Battery: 340 CCA |
| Oil Capacity                            | 2.4 US qt. (2.25 L) w/ Filter                 |

Fits model 5900786, 5900791, 5900793, 5900787 & 5900792

| 32 Gross HP* Briggs & Stratton Vanguard |   |
|---|---|
| Make                                    | Briggs & Stratton                             |
| Model                                   | 543777-0120-E1                                |
| Displacement                            | 54.62 Cu. in (895 cc)                         |
| Electrical Schematic                    | 12 Volt, 20 amp. Alternator, Battery: 340 CCA |
| Oil Capacity                            | 2.4 US qt. (2.25 L) w/ Filter                 |

Fits models 5900794, 5900969, 5900795 & 5900970

| 37 Gross HP† Kawasaki |   |
|-----------------------|---|
| Make                  | Kawasaki                                      |
| Model                 | FX1000V                                       |
| Displacement          | 61 Cu. in (999 cc)                            |
| Electrical Schematic  | 12 Volt, 15 amp. Alternator, Battery: 340 CCA |
| Oil Capacity          | 1.8 US qt. (1.7 L) w/ Filter                  |

Fits models 5900872 & 5900873

| 37 Gross HP† Kawasaki DFI |   |
|---------------------------|---|
| Make                      | Kawasaki                                      |
| Model                     | FX1000V-AS01-S (DFI)                          |
| Displacement              | 61 Cu. in (999 cc)                            |
| Electrical Schematic      | 12 Volt, 15 amp. Alternator; Battery: 340 CCA |
| Oil Capacity              | 1.8 US qt. (1.7 L) w/ Filter                  |

Fits models 5900559

| 30 Gross HP* Briggs & Stratton Commercial Turf |  |
|--|--|
| Make   | Briggs & Stratton                            |
| Model  | 49M977-0114-G5                               |
| Displacement                                   | 49.43 Cu. in (810 cc)                        |
| Electrical Schematic                           | 12 volt, 16 amp alternator; Battery: 340 cca |
| Oil Capacity                                   | 2.1 US qt. (2.0 L) w/ filter                 |

Fits models 5900300 & 5900301

| 36 Gross HP* Briggs & Stratton Vanguard |  |
|---|--|
| Make                                    | Briggs & Stratton                            |
| Model                                   | 613777-0116-G1                               |
| Displacement                            | 60.60 Cu. In (993 cc)                        |
| Electrical Schematic                    | 12 volt, 20 amp alternator; Battery: 340 cca |
| Oil Capacity                            | 2.4 US qt (2.3 L) w/ filter                  |

Fits models 5900560 & 5900561

| 38 Gross HP† Kawasaki |   |
|-----------------------|---|
| Make                  | Kawasaki                                      |
| Model                 | FX1000V-AS01-S (DFI)                          |
| Displacement          | 61 Cu. in (999 cc)                            |
| Electrical Schematic  | 12 Volt, 15 amp. Alternator; Battery: 340 CCA |
| Oil Capacity          | 1.8 US qt. (1.7 L) w/ Filter                  |

†Power Ratings: All power levels are stated gross horsepower per SAE J2723 as rated by Kawasaki and tested per the SAE J1995 test standard. The gross power curves and more information can be viewed at [www.kawasaki-criticalpower.com](http://www.kawasaki-criticalpower.com).

\*Power Ratings: The gross power rating for individual gas engine models is labeled in accordance with SAE (Society of Automotive Engineers) code J1940 (Small Engine Power & Torque Rating Procedure), and rating performance has been obtained and corrected in accordance with SAE J1995 (Revision 2002-05).